

POWER FLAME INCORPORATED



NOVA PLUS

Model NVC Burner Installation & Operation Manual

THE POWER TO MANAGE ENERGY

2001 South 21st Street, Parsons, KS 67357
Telephone: 620-421-0480 FAX: 620-421-0948
Website: <http://www.powerflame.com>
e-mail: CSD@powerflame.com

FOR YOUR SAFETY

If you smell gas:

1. Open windows.
2. Do not touch electrical switches.
3. Extinguish any open flame.
4. Call your gas supplier immediately.

Do not store or use gasoline or other flammable liquids and vapors in the vicinity of this or any other appliance.

WARNING

The improper installation, adjustment, alteration, service or maintenance of this equipment can result in fire, explosion, serious injury, or death. Refer to this manual. For assistance or additional information consult a qualified installer, service agency or the gas supplier.

ATTENTION

All Personnel involved with the startup, maintenance, or adjustment of this burner must read and understand the entire contents of this manual prior to any startup or adjustment made to the burner and related components. Installation and service must be performed by a qualified installer, service agency or the gas supplier.

TABLE OF CONTENTS

	<u>Page Number</u>
1. General Product Information	1
2. Model Identification	2
3. Unpacking and Handling	2
4. Warranty and Spare Parts Information	2
5. Component Information – General	3
6. Installation.....	4
7. Gas Supply Piping.....	4
8. Combustion Air Requirements.....	6
9. Burner Mounting – General	6
10. Combustion Chamber – General.....	7
11. General Start Up Procedures	8
12. Burner Start Up and Service Test Equipment Required	10
13. Burner Start Up Sequence Instructions	10
14. Gas Pilot Ignition Adjustment	15
15. Trouble Shooting Suggestions	16
16. Maintenance	19
17. Burner Startup Information & Test Data	21
18. Owner Operating Instructions.....	22

1 GENERAL PRODUCT INFORMATION

Principal of Operation

The Power Flame NOVA Plus™ Combustion System employs a patented, fully premixed, surface stabilized combustion technology to provide proven ultra-low NOx solutions - Sub 9 to 12 PPM - for commercial, industrial, and process applications. Premixing fuel and air assures complete combustion with minimal levels of CO and unburned hydrocarbons. The all metallic firing head guarantees reliable and consistent performance at the operating conditions necessary to provide single digit NOx emissions. The NOVA Plus is a simple, cost effective, field proven system designed to meet today's most stringent emissions requirements. Power Flame provides a U.L. listed, factory tested package tailored to your job specific requirements up to NVC10. The NOVA Plus is suitable for use on firetube and watertube boiler applications, as well as process heaters. It will operate with uniform heat flux and excellent flame stability over a broad range of operating conditions.

The modular concept that is the basis for all Power Flame burners keeps the initial investment low and maintenance costs at a minimum across the life of the burner. The NOVA Plus is fitted with a state of the art control system and integral panel.

Combustion air flow is controlled by a multi-louvered damper assembly. Combustion air is supplied by an integral motor-driven blower, which discharges into the burner mixing spool assembly. Gaseous fuel and air mix in the burner mixing spool. The premixed gaseous fuel and air flow down the center plenum of the cylindrical element and through the metal material. Ignition occurs on the outer surface.

The air-fuel ratio is established at the time of start-up and proven with combustion test equipment to provide the lowest practical oxygen with a clean flame and single digit NOx emissions.

A Flame Safeguard Controller programs the firing cycle. The operating cycle is sequenced to ensure normal and safe conditions before fuel can be introduced into the combustion chamber area. The complete firing cycle is supervised to ensure that ignition of main flame is properly established and maintained. Flame monitoring is provided by an ultraviolet type scanner.

The limit circuit includes the operating limit control to maintain a set operating pressure or temperature, as well as a high limit control to guard against excessive pressure or temperature. Low water and other similar safety controls can be interlocked into the burner control system to satisfy specific job and/or code requirements.

The control circuit is normally 120 volts. A control circuit transformer may be furnished to provide the 120 volt control circuit for a polyphase motor application.

The pre-wired Control Panel is mounted and wired as an integral part of the burner in accordance with recommendations of Underwriters Laboratories, Inc. and The National Electrical Code. Components are wired to numbered terminal strips. Panel and burners are factory fire tested before shipment. Comprehensive wiring and gas piping diagrams are furnished with each burner in accordance with individual job or application requirements. Wall mounted or free standing control panels are also available.

Power Flame Model NVC burners are available with control systems to comply with the requirements of Factory Mutual, GE GAP and any special state, municipal, local and utility company codes, including New York City Department of Buildings (MEA), Commonwealth of Massachusetts, State of Connecticut Fire Marshall, Illinois School Code and others.

2. MODEL IDENTIFICATION

The numerical suffix after the letters NVC denotes the burner frame size. The letter R inserted immediately after the letters NVC denotes an inverted blower configuration.

The alphabetical designation immediately following the frame size indicates the fuel to be used: G is gas only. The numbers following the fuel designation indicate the nominal size of the gas train (30 = 3.0”).

Model NVC9-G-30	Fuel (gas)
	Standard gas train size (3.0”)

Any alphabetical suffix (such as A, B, etc.) to the fuel designation denotes special product coding (consult factory).

3. UNPACKING AND HANDLING

Power Flame Model NVC burners are usually shipped as a unit with an integrally mounted, pre-wired control panel. Gas train components may be pre-piped as an option or shipped loose for field mounting.

Uncrate the burner carefully and check all parts received against the computer generated Burner Specification Sheets supplied by Power Flame. Components not mounted on the burner (shipped loose) are designated with an L in the left hand column on the sheets. Claims on shortage or damage must be immediately filled with the carrier.

4. WARRANTY AND SPARE PARTS INFORMATION

Power Flame offers a 15 month Limited Warranty on all components from the date of shipment (see inside of back cover for details).

The Owners Information envelope packed with the burner contains a Warranty Registration Card. The Warranty Registration Card is also a request form for a computer generated Spare Parts List. An on-hand supply of spare parts is highly recommended in case of emergency shutdown. The pre-addressed, postage paid Warranty Registration Card should be completed and returned to Power Flame. In the event that the Warranty Registration Card is lost, please contact Power Flame’s Customer Service Department in Parsons, Kansas or you may register on-line through the Power Flame website (www.powerflame.com). All communications with the factory will be handled more efficiently if the burner is identified by the burner model, serial and job numbers. This information is stamped into the burner nameplate that is attached to the integral control panel (or to the burner, when remote control panels are supplied).

5. COMPONENT INFORMATION – GENERAL

The contents of this manual are general in nature, due to the wide variety of equipment specifications, insurance requirements, state, local and other applicable codes.

The computer generated Burner Specification Sheets, shipped with the burner, represent the As-Built version of your specific Power Flame combustion system. Part numbers and component descriptions will match those components supplied. A duplicate set of Burner Specification Sheets is available through Power Flame's Customer Service Department or through the secured area of our website.

- The components and arrangements shown are typical for a Model NVC-G burner. In some cases, the type of components and/or their arrangement may vary from this depiction. For specifics on your system, refer to the technical information supplied with the burner.

Figure 1
Burner Component Identification
Typical for Model NVC-G

1. Blower Motor
2. Mixing Spool
3. Prefilter/Filter
4. Fan Housing
5. Filter Switches (2)
6. Gas Pilot Regulator
7. Flame Scanner
8. Gas Pilot Air Supply Line
9. Gas Pilot Ignition Transformer
10. Burner Element
11. Air Pressure Switches (LFS), (Element)
12. Modulation Motor
13. Control Panel

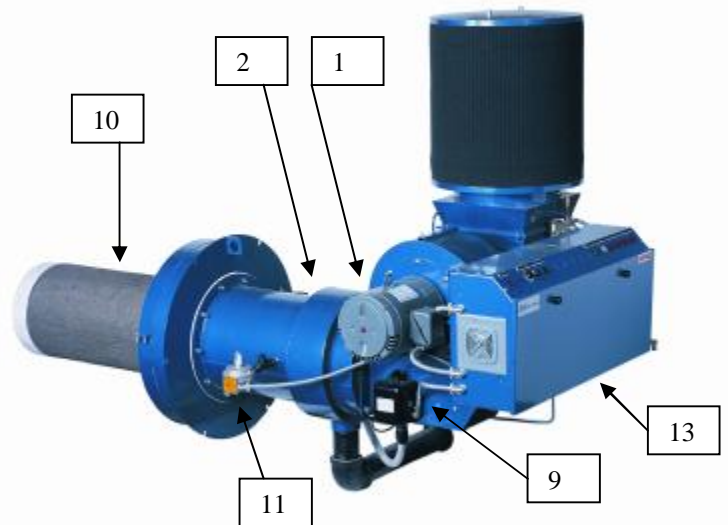
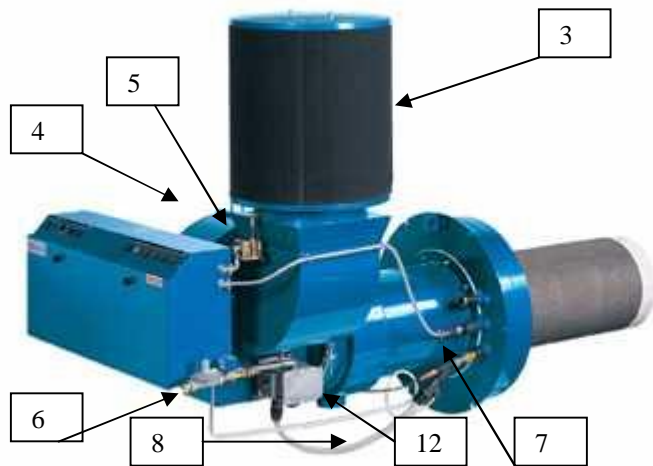

**Figure 2
Model NVC Dimensions**

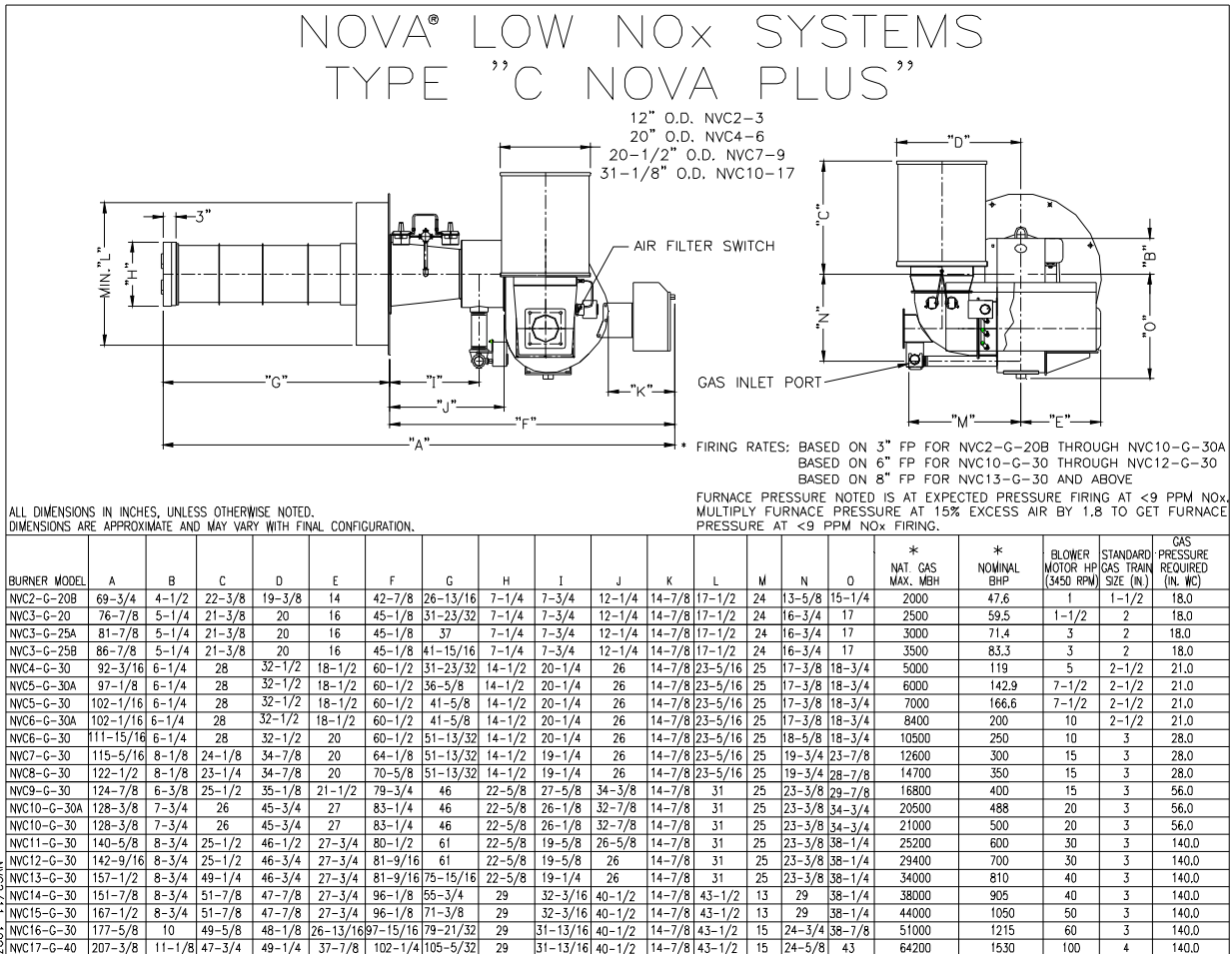

6. INSTALLATION

The installer should contact the local gas utility relative to available supply pressures, limitations on allowable pressures in the building, general piping requirements and applicable codes, restrictions and regulations. Considerations of these types, as well as written permits and other state, city and local codes should be discussed with and approved by the appropriate governing bodies.

7. GAS SUPPLY PIPING

Gas piping should be sized to provide required pressure at the burner train inlet manual shutoff cock, when operating at the maximum desired fuel input.

All gas piping should be appropriately pressure tested to ensure leak free operation. It is recommended that a dirt pocket or trap be piped into the gas supply system just ahead of the burner train inlet manual shutoff cock.

When testing with pressures higher than the maximum pressure ratings of the gas train components, be sure to isolate these components and test their piping for gas leaks with correct pressures only.

Refer to Table 1 for information relating to the sizing of gas supply piping. These charts are based on the general flow characteristics of commercially produced black carbon steel pipe. If in doubt regarding flow capabilities of a chosen line size, the next largest size is recommended.

Refer to Figure 3 for the typical gas piping schematic to meet U.L. requirements in the NVC burner firing ranges.

Table 1

Capacity of Pipe – Natural Gas (CFH)
With Pressure Drop of 0.3" w.c. and Specific Gravity of 0.60

Table 1A

Correction Factors

Pipe Length In Feet	Pipe Size – Inches (IPS)							Specific Gravity Other Than 0.60		Specific Drop Than 0.3	
	1	1-1/4	1-1/2	2	2-1/2	3	4	Specific Gravity	Multiplier	Pressure Drop	Multiplier
10	520	1050	1600	3050	4800	8500	17500				
20	350	730	1100	2100	3300	5900	12000				
30	285	590	890	1650	2700	4700	9700	0.50	1.10	0.1	0.577
40	245	500	760	1450	2300	4100	8300	0.60	1.00	0.2	0.815
50	215	440	670	1270	2000	3600	7400	0.70	0.926	0.3	1.00
60	195	400	610	1150	1850	3250	6800	0.80	0.867	0.4	1.16
70	180	370	560	1050	1700	3000	6200	0.90	0.817	0.6	1.42
80	170	350	530	990	1600	2800	5800	1.00	0.775	0.8	1.64
90	160	320	490	930	1500	2600	5400	Propane - Air		1.0	1.83
100	150	305	460	870	1400	2500	5100	1.10	0.740	2.0	2.58
125	130	275	410	780	1250	2200	4500	Propane		3.0	3.16
150	120	250	380	710	1130	2000	4100	1.55	0.662	4.0	3.65
175	110	225	350	650	1050	1850	3800	Butane		6.0	4.47
200	100	210	320	610	980	1700	3500	2.00	0.547	8.0	5.15

Note: Use multiplier at right for other specific gravities and pressure drops.

Table 2

Equivalent Length of Fittings in Feet

Pipe Size (IPS)	1.0	1.25	1.5	2	2.5	3	4
Std tee through side	5.5	7.5	9.0	12.0	14.0	17.0	22.0
Std. E11	2.7	3.7	4.3	5.5	6.5	8.0	12.0
45° E11	1.2	1.6	2.0	2.5	3.0	3.7	5.0
Plug Cock	3.0	4.0	5.5	7.5	9.0	12.0	16.0

Figure 3
Typical Gas Piping Schematic for Model NVC Burner, UL Listed.

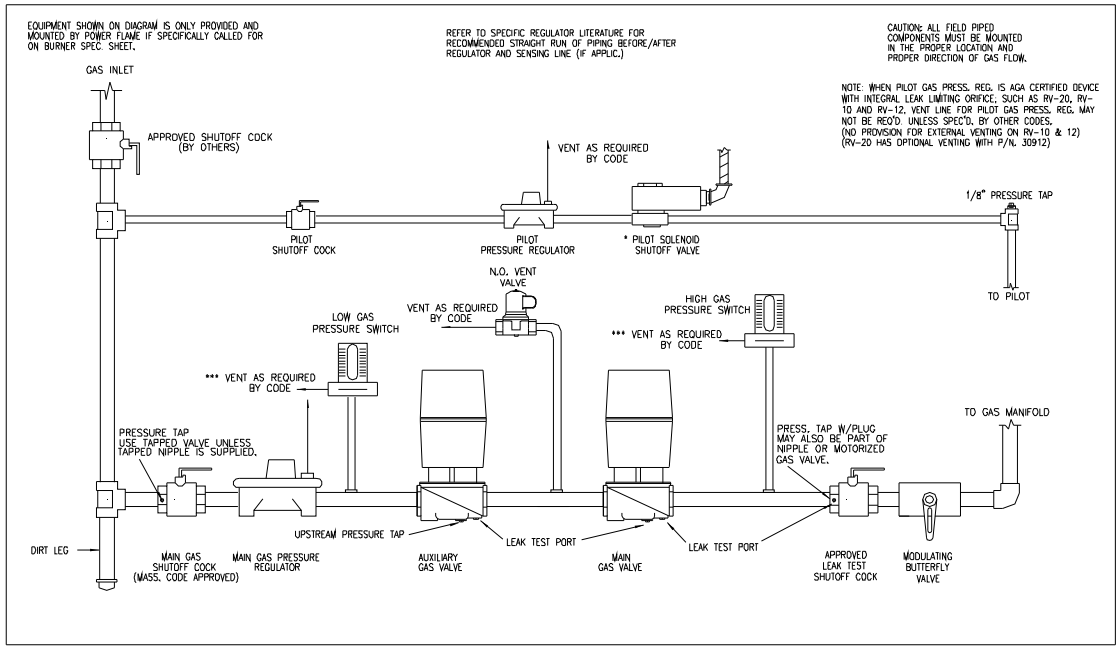

8. COMBUSTION AIR REQUIREMENTS

Fresh air required to support combustion, as well as to provide adequate location ventilation, must be supplied. All types of fuel require approximately 10 cubic feet of standard air (sea level at 60°F) per 1000 BTU's firing rate, for theoretical perfect combustion. In actual practice, the premix burner will require approximately 60% more air to achieve the NOx reduction and to ensure complete combustion, but this can vary substantially with specific job conditions. Additional air is lost from the boiler room through barometric dampers, draft diverters and similar venting devices. It is generally accepted that 1/2 square inch of free air opening (for each burner in the room) per 1000 BTU/hr firing rate will be adequate. Under no circumstances should a boiler room be under negative pressure. Jurisdictional authority relating to combustion air and boiler room ventilation requirements vary widely. In order to make certain compliance, the controlling authorities should be consulted.

9. BURNER MOUNTING – GENERAL

Provisions should be made to provide adequate space around the burner and associated equipment to allow for ease of inspection, maintenance and service.

Observe codes for the minimum clearances to combustibile materials.

The burner mounting flange must be securely attached to the front plate with suitable gasket or non-asbestos, high temperature rope packing to prevent any products of combustion from escaping from the combustion chamber through the burner-boiler mounting flanges. The burner assembly must be supported at the base of the housing to prevent undue strain on the front plate. (A mounting pedestal is furnished for this purpose.)

10. COMBUSTION CHAMBER – GENERAL

Combustion chambers shall be provided as recommended in Chamber Dimension Charts. A minimum of six inches must be maintained around the burner element.

Certain types of heat exchangers, such as warm air furnaces, some hot oil heaters, wet base steel, packaged firebox boilers and Scotch Marine boilers, use the combustion chamber to transfer heat and therefore do not require refractory or other insulation. If in doubt, consult the heat exchanger equipment manufacturer.

All possible points of air infiltration or ex-filtration must be sealed. If the unit is to be fired under positive combustion chamber conditions, extreme care must be taken to ensure that a 100% seal is maintained. The Model NVC burner is designed to provide all the air required for complete and efficient combustion. Entry or loss of air from sources other than the firing unit will decrease its' overall combustion and operational efficiency.

Figure 7
Chamber Dimension Charts
Scotch Marine Boiler Minimum Furnace Tube Inside Diameters

BHP	Min. Inside Dimension
50	20"
100	26"
200	29"
300	34"
400	38"
500	38"
600	42"
700	45"
800	50"
900	50"
1000	50"
1200	54"
1500	54"

Note: The above dimensions are recommended minimums. If boiler dimensions are less than indicated, consult with the factory.

11. GENERAL START UP PROCEDURES

General Start Up

A thoroughly qualified burner technician must be employed to provide the initial burner start up, as well as any subsequent servicing of the burner and related controls.

A representative of the owner and/or the person or persons responsible for operating and maintaining the unit should be present during the initial start up. A service representative may also be required by the local utility on gas-fired equipment. Instructions regarding the proper care and maintenance of the unit should be outlined with these people present.

Before initiating start up, the start up technician should thoroughly study and become completely familiar with the exact sequence of operation and all other details of the specific flame safeguard control system being used. This information will be found in bulletins printed and supplied by Autoflame, Honeywell, Fireye, or Siemens. A copy of this bulletin is supplied with the burner in the Owners/Installers Packet.

After the burner is mounted and all wiring and piping has been completed, tested and determined to be correct, the following procedures are recommended:

1. Make a general inspection of the equipment room to ensure that the installation is complete. Check piping, controls, wiring and etc.
2. Close main and checking gas cocks.
3. Tighten all screws on terminal blocks in control cabinet in case some may have loosened in shipment.
4. Check fuses in main panel (if supplied) and in burner control cabinet. Check wiring to the burner control cabinet for compliance with the wiring diagram and local codes. Determine that voltage supply is correct to motor starter line connections and to control circuit line connections. If a control circuit transformer is supplied, make certain its primary voltage matches the line voltage being supplied. (A 230 volt transformer does not produce proper control voltage when supplied with 208 volts).
5. Check breaching and stack to ensure that they are open and unobstructed.
6. Check blower rotation by momentarily making contact of the motor starters. Proper rotation is imprinted on the fan housing.
7. Check operating controls, limit controls, low water cut-off, flame safeguard control reset, high and low gas pressure switches (if used), low fire interlock switch (if used) and all other applicable interlocks. All contacts should be closed (an exception will be found on jobs using the low gas pressure switch; this switch should be open until the main gas cock is opened).
8. Do not repeatedly recycle the burner, as to allow any unburned fuel in the combustion chamber to collect. Allow 5 minutes between recycles.
9. Specific instructions relative to component sequencing are provided in the flame safeguard manufacturer's bulletin which is included with the documentation shipped with the burner.

10. Proper test equipment must be used in order to achieve maximum system operational reliability and fuel efficiencies. See page 13 for equipment lists.
11. All fuel/air adjustments should be made to achieve required input rate, satisfactory combustion test values, flame stability and appearance. Before start up determine the burner's manifold pressure, see **Figure 9**, (Approximate High Fire Manifold Pressure). The pressures shown (Total) are the approximate net pressure, therefore the heat exchanger's over-fire pressure must be added to these pressures for the total manifold pressure.

Figure 9
Approximate High Fire Manifold Pressures

<u>Burner Model</u>	<u>Mixing Spool Orifice Qty/Size</u>	<u>Firing Rate CFH</u>	<u>Orifices + Element =</u>		<u>Total</u>
NVC2	(8).313	2,000	3.86"	5"	8.8"
NVC3 (20)	(8).344	2,500	4.17"	5"	9.1"
NVC3 (25)	(8).375	3,000	4.24"	5"	9.2"
NVC3 (25B)	(8).406	3,500	4.15"	5"	9.2"
NVC4	(6).577, (6).531	5,000	1.16"	5"	6.2"
NVC5A	(6).577, (6).531	5,520	1.42"	5"	6.4"
NVC5	(6).577, (6).531	7,000	2.29"	5"	7.3"
NVC6A	(6).577, (6).531	8,400	3.29"	5"	8.3"
NVC6	(6).577, (6).531	10,500	5.15"	5"	10.2"
NVC7	(6).620, (6).531	12,600	5.85"	5"	10.9"
NVC8	(6).620, (6).531	14,700	7.98"	5"	13.0"
NVC9	(8).646, (8).625	16,800	3.98"	5"	9.0"
NVC10A	(8).646, (8).625	18,860	5.00"	5"	10.0"
NVC10	(8).646, (8).625	21,000	6.21"	5"	11.2"
NVC11	(8).646, (8).625	25,200	8.9"	5"	13.9"
NVC12	(20).709	29,400	5.0"	5"	10.0"
NVC13	(20).709	33,600	6.58"	5"	11.6"
NVC14	(16).834	37,800	6.8"	5"	11.8"
NVC15	(16).834	42,000	8.45"	5"	13.5"
NVC16	(16).834	50,400	12.16"	5"	17.1"
NVC17	(16).834	63,000	19.01"	5"	24.0"

12. Every new burner startup should employ the use of the Burner Start Up Information and Test Data sheets on **pages 24 and 25**.

The gas system uses two motorized gas shutoff valves to control the on/off flow of the gas. A modulating motor or servo motor (depending on the control scheme) controls the positioning of a butterfly type Gas Proportioning Valve. When the modulating motor is employed it also controls the positioning of the combustion air dampers, while a second servo will control the air dampers when servos are used.

12 BURNER START UP AND SERVICE TEST EQUIPMENT REQUIRED

The following test equipment is required to ensure proper start up and adjustment of burner equipment to obtain maximum efficiency and reliability of operation.

For any Gas	
Flue Gas Analyzer with O ₂ , NO _x , CO capability (Required)	U-Tube manometer 0-16" W.C. or calibrated 0-10" and 0-35" W.C. pressure gauges.
Stack thermometer	PSIG 0-5#
Draft gauge or inclined Manometer	(Higher pressure ranges may be necessary depending upon gas inlet supply pressure)
Combination volt/ammeter	
D.C. microammeter or D.C.	Voltmeter, as required by Flame safeguard

Measure the excess O₂ and test for CO to make certain that the burner is adjusted so that it has an excess O₂ of typically 6% to 9% when firing without FGR (flue gas recirculation). The excess O₂ level when using FGR will typically be 5% to 7%. This is the typical excess O₂ range required for the premix burner to obtain reduced NO_x emissions. If higher excess O₂ is required to obtain a particular emission level the CO level must be checked thoroughly. CO is a dangerous product of incomplete combustion and is associated with combustion inefficiency and increased fuel cost. Any CO readings on any fuel should be near 0% or less than 50 ppm.

13. BURNER START UP SEQUENCE INSTRUCTIONS

1. Prior to burner start up – contact the local gas company to determine if any correction factors have to be applied to their indicated meter flow rates. This information is important as relates to achieving specific heat exchanger BTU/HR inputs. **Refer to page 12** and the burner rating plate for additional firing rate information.
2. Refer to **Figure 10** for air switch locations and pressure settings.
3. Refer to the gas piping diagram furnished with the burner. Check gas piping, controls and valves for leaks and compliance with codes.
4. Check all linkages and servo couplings for proper position and tightness
5. Close main checking and pilot gas cocks. Install one gas pressure gauge on the manifold (orifice tee) to read burner firing head pressure (use 0-32" W.C. gauge or a manometer). Install a second gas pressure gauge to read gas supply pressure between the main gas cock and the inlet to the main gas pressure regulator (use a 0-5 psi gauge or as appropriate). If there is no tapping in this location, install a tee at the point where the pilot gas supply is connected to the main gas line. Slowly open the main gas cock in order to determine that the incoming gas pressure is within the specified limits of the main and pilot gas pressure regulators, automatic fuel valves and gas pressure switches.

6. Disconnect pilot line at inlet to the pilot gas pressure regulator and purge air from the pilot gas line. Purging of gas lines must be done in accordance with NFPA 54 of the National Fire Protection Association's National Fuel Gas Code. After the air is purged from the gas supply system, close the pilot cock and reconnect the pilot line. Leave the pilot cock closed.

Figure 10
Air Switch Locations

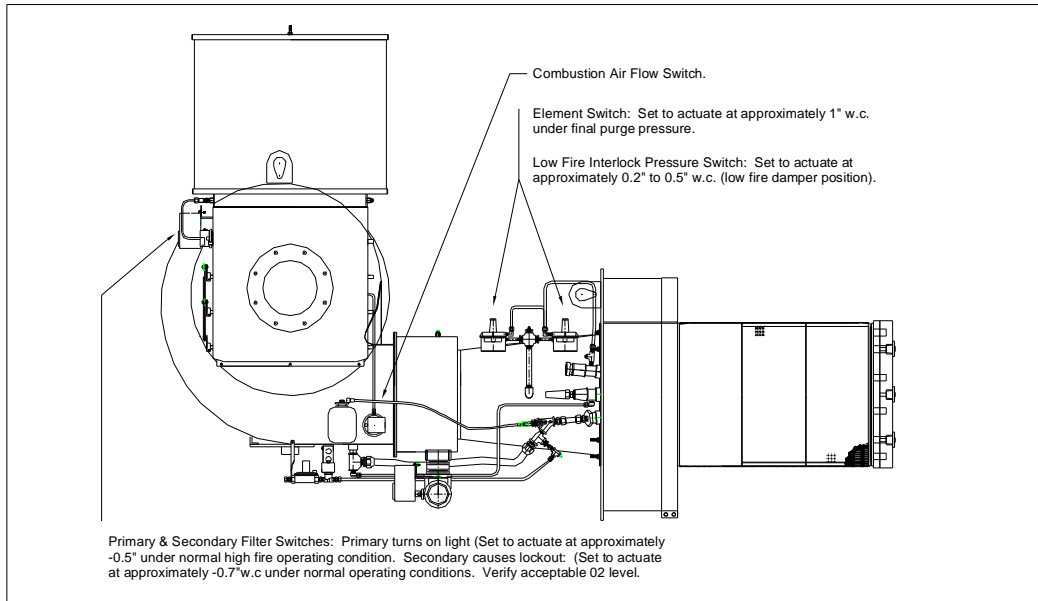

7. Install required system measuring devices: a) appropriate flame signal meter to the flame safeguard control; b) manometer (or 0-10" W.C. gauge) in the pilot test tee port; c) stack thermometer and O₂ sample line to the breaching; and d) draft gauge to the combustion chamber test point.
8. It is strongly recommended that an automatic gas valve bubble leak test be performed in accordance with the gas valve manufacturer's instructions on every new installation and periodically afterwards in order to ensure that the valve is functioning according to the manufacturer's specifications. It is also suggested that the test be conducted during a normal pre-purge burner operation. This test will reveal any problems that relate to incorrect wiring of the automatic gas valve that could cause premature energizing of the valve.
9. Set the air dampers to the low fire position prior to light-off. This position is determined by first installing a water tube manometer on the mixing spool air pressure tap, then with the blower motor running adjust the damper position until approximately 0.2" to 0.5" w.c. (typical low fire air setting) is obtained on the manometer. At this point also confirm that motor rotation is correct.

10. Re-start the burner. With the pilot gas cock closed, the burner will go through a blower pre-purge period, after which the gas pilot ignition transformer will be energized, although no pilot will be established. (At no time should there be any flame signal reading, nor should the main gas valve attempt to open.) At the end of the pilot trial for ignition and blower purge period, the flame safeguard control should shut the system down in a safety lockout mode, requiring manual reset of the flame safeguard control to restart the burner.
11. Wait three minutes, reset the flame safeguard control safety switch (restarting the burner) and open the pilot gas cock. When the blower pre-purge period ends and the burner is energized – if the flame safeguard control has a test/run switch – flip the switch to the test position while the pilot is on and make adjustments as required. **See page 18** for pilot ignition adjustments. Recycle the burner several times to make certain pilot operation is reliable.
12. With pilot adjustments completed, reset the switch to the Run position, which will allow the sequence to proceed to the automatic gas valve energizing position.
13. When the main automatic gas valve begins to open, slowly open the checking gas cock to light off the main flame. The main flame should light immediately. If not, it may be necessary to eliminate air from the main gas line and/or adjust main gas pressure regulator flow rates.
14. Adjust the burner as necessary to provide smooth ignition of the main flame. If the flame signal drops significantly when the main automatic gas valve opens, slightly increase the pilot gas pressure to attain a stable flame signal value.
15. Refer to items 27 and 28 carefully for recommended limit control and other control devices operational checkout.
16. Initial adjustments should be made at the low fire position. All Power Flame burners are factory tested and adjusted. However, to determine that the metering butterfly valve is, in fact, in the low fire position, observe the end of the metering valve shaft. The slot in the end of the shaft indicates the position of the valve. When the slot is in the horizontal position (parallel with the gas flow direction), the valve is fully open. On servo operated systems, verify the valve position by viewing through the end of the pipe.
17. Tighten (finger tight) the hex bolt to the linkage rod at the swivel on the modulating motor driver arms and run the motor through its full travel to ensure that the linkage is free and that limits on the metering device and air dampers are not exceeded.
18. Turn the burner on and let it advance to the main flame light off position. Take action as necessary to hold the linkage at the low fire position by using a manual potentiometer or electrically disconnecting the modulating motor. Power Flame burners are tested at the factory and linkage adjustments for modulation are made at that time.
19. With the burner in the factory set low fire position, (verify by checking mixing spool air pressure of typically 0.2" to 0.5") adjust air and fuel linkage to good fuel/air ratio low fire settings (6 – 9% O₂ little or no CO). Mark the linkage at the new settings.
20. Increase the firing rate to the midway point. Set the fuel/air ratios to achieve good combustion values (6 - 9% O₂ little or no CO). Mark the linkage as a reference point for this new mid fire position.

21. Increase the rate to high fire position and repeat the test done for the mid point adjustment. Results should range in the area of 6% to 9% O₂ with little or no CO. The metering device setting and air damper openings should be marked and noted to obtain high fire reference points. Note that an additional point of fire adjustment may be obtained by modifying the regulated gas pressure delivered to the burner metering device. The burner pressure regulator is used to obtain this adjustment and can be used within available pressure limits to obtain optimum firing conditions.
22. On linkage systems, operate the modulating lever arm on the modulating motor through the three previously referenced points. Minor setting modifications may be required to ensure that the reference points are acquired.
23. Determine that the required gas input rate is being achieved by clocking the gas flow at the gas meter. The gas utility should be consulted to determine if any correction factors have to be applied to the indicated meter flow rates.
24. Intermittently operate the burner until the water is warm in the boiler, or follow specific initial firing recommendations provided by the heat exchanger manufacturer.
25. Tighten all linkages and permanently mark settings.
26. Limit control check should be made as follows:
 - A) Permit the burner to run until the limit control settings have been reached.
 - B) The burner should turn off when the set temperature or pressure has been reached. Set the controls so that the burner will go to the low fire position before the operating limit control turns the burner off.
 - C) After a differential pressure or temperature drop, the burner should re-start automatically.
 - D) With the unit running normally, open the blow down valve and remove water to the point below the Low Water Cut Off setting. The burner should turn off and re-start automatically when the proper water level is re-established. (If a manual reset type Low Water Cut Off is used, it will have to be reset.)
27. Set and check operation of:
 - A) Low and high gas pressure switches. See gas pressure switch manufacturer's instructions for detailed procedures.
 - 1) For initial start up:

Once the burner's normal operational gas pressure has been set, adjust the low and high gas pressure switches as follows:

 - (a) Low gas pressure switch. With the burner running, slowly close the main gas train manual shutoff cock and adjust the switch to open its circuit when the pressure falls to a maximum of 50% below its normal value. The burner will shut down. Open the

manual gas shutoff cock to the full open position and manually reset the Low Gas Pressure Switch. The burner will re-start.

- (b) High gas pressure switch. With the burner running, adjust the switch to a point where the switch opens its circuit. The burner will shut down. Manually reset the switch and re-adjust the cutout point to be made at the normal operating pressure, but to open as the pressure goes slightly above normal or to a maximum of 50% above.

B) All burner and heat exchanger controls and operating devices.

C) Blower Combustion Air Flow Switch.

- 1) Shut burner power off.
- 2) Disconnect both wires at the air flow switch and temporarily clip them together. Make sure that they cannot ground against anything, since they will be powered with 110 volts during the test.
- 3) Put a continuity meter across the common and normally open terminals on the air switch.
- 4) Close the gas train checking cock.
- 5) Start the blower motor. The meter should read electrical continuity as soon as the blower starts.
- 6) Disconnect the wire which energizes coil of blower motor relay (starter), or open the main power disconnect switch to the burner. Within 3 to 4 seconds after the blower motor is de-energized, the meter should indicate an open air flow switch circuit (no continuity).
- 7) If the switch does not open in 3 to 4 seconds, re-adjust accordingly. Turn the air flow switch adjustment screw clockwise to shorten cut-off response time and counter-clock-wise to lengthen cut-off response time.
- 8) Turn the burner power off. Remove the shorting clip from the two disconnected wires and let them hang loose (they will be powered with 110 volts, so don't let them ground out).
- 9) Open the gas train checking cock. Turn the burner on. With the wires disconnected, the burner should go into a purge cycle, although neither the ignition nor the main fuel valve circuits will be energized. If they do energize, there is a wiring problem. Correct as required.
- 10) Turn power off. Reconnect the air flow switch wires to the air flow switch terminals. Place burner back into normal operation.

28. The Owner's Operating Instructions, page 26 of this manual, should be posted in a clearly visible location close to the burner.

29. If the burner operation is abnormal, refer to Trouble Shooting Suggestions, as well as trouble shooting information included in the flame safeguard manufacturer's bulletin shipped with the burner. It is also strongly suggested that all test procedures outlined in the flame safeguard control manufacturer's bulletin be conducted.
30. Complete the Burner Start Up Information and Test Data sheets on page 24.

14. GAS PILOT IGNITION ADJUSTMENT

Excessive gas pressure and insufficient air are the most common causes of pilot ignition failure.

Gas pressure should be read at the test tee on the pilot gas supply pipe with a manometer or 0 – 10" W.C. gauge. Look for stability of gas pressures at all times. Some job conditions or heat exchangers may require larger air damper openings or different gas pressures than recommended. For dependable pilot ignition, always use air damper setting to provide the MOST air and LOWEST pilot gas pressure settings allowable for good pilot signal at all times.

1. Remove pilot assembly and check for proper orifice size and spark gap. The spark gap between the electrode and inside radius of the gas pilot assembly should be 1/8" – 3/32". See Figure 11.

FIGURE 11. TYPICAL PILOT

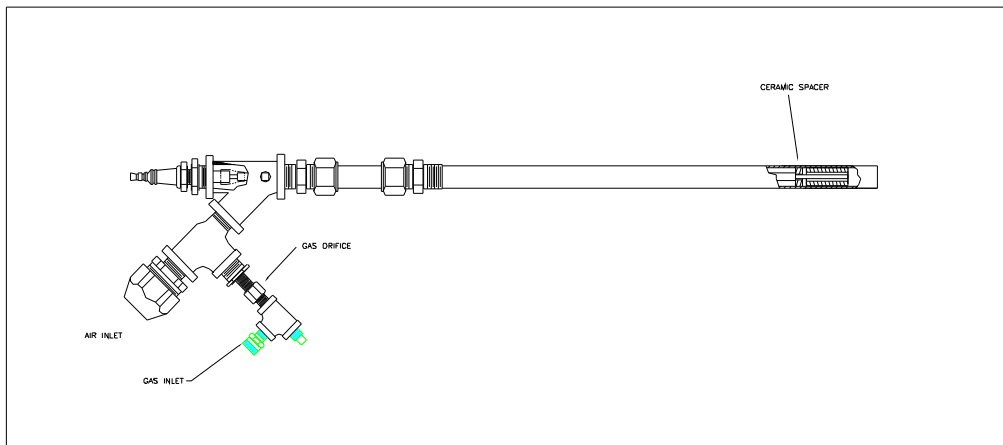

2. Close checking cock (main test cock). Start up burner and flip run/test switch to test.
3. Observe pilot signal with DC voltmeter or micro-ammeter and reduce pilot gas pressure to a point where the signal is erratic or reduced substantially from initial reading.
4. Raise the pilot gas pressure to the point where the signal is again stable. Remove scanner and use a mirror to view the pilot flame through the scanner pipe (a live flame from cigarette lighter or butane torch may be needed to keep scanner actuated). Be sure to get full coverage of scanner pipe by pilot flame.

Release check switch and observe meter as main gas valve opens. If there is a drop in signal as this happens, increase pilot pressure slightly until signal is steady at all times.

Table 12
Acceptable Stable Pilot and/or Main Flame Current Readings

<u>Control</u>	<u>U.V.</u>	<u>Infrared</u>
R7800	1.25-5.0 DC Volts	1.25-5.0 DC Volts
E110	10 min., 20 or greater normal	10 min., 20 or greater normal

15. TROUBLE SHOOTING SUGGESTIONS

1. Burner Fails to Start

- A. Defective On/Off or fuel transfer switch. Replace
- B. Control circuit has an open control contact. Check limits, low water cutoff, proof of closure switch and others as applicable.
- C. Bad fuse or switch open on in-coming power source. Correct as required.
- D. Motor overloads tripped. Reset and correct cause for trip out.
- E. Flame safeguard control safety switch tripped out. Reset and determine cause for apparent flame failure.
- F. Loose connections or faulty wiring. Tighten all terminal screws and consult wiring diagram furnished with the burner.
- G. Flame safeguard control starting circuit blocked due to flame relay being energized. Possible defective scanner – replace. Possible defective amplifier – replace. Scanner actually sighting flame due to leaking fuel valve – correct unwanted flame cause. Defective flame safeguard control – replace.
- H. Defective blower motor. Repair or replace.
- I. LFI air switch open. Verify damper is in the low fire position or reset switch.

2. Occasional Lockouts For No Apparent Reason

- A. Gas pilot ignition failure. Refer to pilot adjustment section and readjust to make certain that the ignition is instant and that flame signal readings are stable and above minimum values. Use a manometer or 0 to 10" W.C. gas pressure gauge on pilot test tee to make certain that pressure is as recommended.
- B. Gas pilot ignition. Verify that there are no cracks in the porcelain and that transformer end and electrode end plug in connections are tight.
- C. Loose or broken wires. Check all wire nut connections and tighten all terminal screw connections in panel and elsewhere as appropriate.
- D. Ensure that when main flame lights, the air flow switch is not so critically set as to allow occasional momentary opening of the air switch contacts.

- E. Occasional low voltage supply. Have local utility correct. Make certain that the burner control circuit transformer (if supplied) is correct for the voltage being supplied.
- F. Occasional low gas supply pressure. Have utility correct.
- G. Element air pressure switch opens during purge. Reset switch to remain closed just under maximum purge pressure.

3. Burner Motor Runs, but Pilot Does Not Light

- A. Gas supply to burner shut off – make sure all manual gas supply valves are open. Automatic high pressure valve at meter such as Sentry type tripped shut due to high gas pressure – reset valve and correct cause for trip out.
- B. Pilot solenoid valve not opening – listen and feel for valve actuation. Solenoid valve not being powered – check electrical circuitry. Replace coil or entire valve if coil is burned out.
- C. Defective gas pilot regulator – replace.
- D. Gas pressure too high or too low at pilot orifice. Check orifice size in gas pilot assembly. Replace if incorrect. Refer to gas pilot adjustments for correct settings. Readjust as required.
- E. Defective ignition transformer – replace. Incorrect ignition electrode settings – refer to gas pilot adjustments for correct settings.
- F. Defective flame safeguard control or plug in purge timing card. Replace as required.
- G. Air flow switch not making circuit – check out electrically and correct pressure adjustment on switch, if required. Defective air flow switch – replace. Air switch negative pressure sensing tube out of position – reposition as necessary.

4. Burner Motor Runs and Pilot Lights, but Main Gas Flame Is Not Established

- A. Main shutoff or test cock closed. Check to make certain fully open.
- B. Pilot flame signal reading too low to pull in flame safeguard relay. Refer to gas pilot settings section and readjust as required.
- C. Defective automatic main or auxiliary gas shut off valves. Check electrical circuitry to valves. Replace valves or correct circuitry as required.
- D. Defective flame safeguard control or plug in amplifier. Check and replace as required.
- E. Butterfly valve set incorrectly on modulating burner. Readjust as required.

- F. Main gas pressure regulator atmospheric vent line obstructed. Correct.
- G. Defective main gas pressure regulator – replace. Misadjusted main gas pressure regulator – readjust to meet required operational values.

5. Carbon Monoxide Readings Too High

- A. Flame impingement on cold heat transfer surfaces caused by excessive firing rate. Reduce firing rate to correct input volume.
- B. Flame impingement on cold combustion chamber surfaces due to undersized combustion chamber. Refer to chamber size charts, page 10, and/or contact factory for additional information.
- C. Incorrect gas/air ratios. Readjust burner to correct CO₂ / O₂ levels, reducing CO formation to appropriate level.

6. High Fire Input Cannot Be Achieved

- A. Gas company pressure regulator or meter operating incorrectly, not allowing required gas pressure at burner train inlet. Have gas company correct.
- B. Gas cock upstream of train inlet not fully open. Check and correct.
- C. Gas line obstructed. Check and correct.
- D. Gas train main and/or leak test cocks not fully open. Check and correct.
- E. Gas supply line between gas company regulator and burner inlet too small. Check supply pressure at meter, determine pressure drop and increase line size as required, or raise supply pressure to compensate for small line. Do not raise pressure so high that under static (no flow) conditions the pressure exceeds the maximum allowable pressure to the gas train components on the burner.
- F. Burner gas train components sized too small for supply pressure. Increase component size as appropriate.
- G. Automatic gas valve not opening fully due to defective operation. Replace gas valve.
- H. Butterfly valve not fully opened. Readjust.
- I. Defective main gas pressure regulator. Replace
- J. Incorrect spring in main gas pressure regulator. Replace as required.
- K. Main gas pressure regulator vent line obstructed. Check and correct.
- L. Normally open vent valve (if supplied) not closing when automatic gas valves open. Check to see if valve is fully closed when automatic valves are open. Replace vent valve, if not closing fully.

16. MAINTENANCE

General Information

Only qualified service technicians should make mechanical or electrical adjustments to the burner and/or associated control equipment.

Preventive maintenance can usually be performed by building maintenance or operating personnel.

Always follow the information provided in the Owner Operating Instructions on page 25. These should be conspicuously posted in the burner room at the time of the initial burner installation and startup.

Always turn the power supply off to the burner and close manual fuel valves as appropriate for routine maintenance.

Make sure that combustion and ventilation fresh air sources to the burner room remain clean and open.

Periodically check all electrical connections and make sure the flame safeguard control chassis is firmly connected to its wiring base.

Refer to manufacturer's product bulletins supplied with the burner for maintenance on the flame safeguard control and other components.

PERIODIC CHECK LIST

<u>Item</u>	<u>Frequency</u>	<u>Checked By</u>	<u>Remarks</u>
Gages, monitors and indicators	Daily	Operator	Make visual inspection and record Readings in log
Combustion Air Filter	Daily	Operator	Make visual inspection of filter and indicator light
Instrument and equipment settings	Daily	Operator	Make visual check against heat exchanger manufacturer's recommended specifications
Firing rate control	Weekly Semiannually Annually	Operator Service Technician Service Technician	Verify heat exchanger manufacture's settings Verify heat exchanger manufacture's settings Check with combustion test
Flue, vent, stack or outlet damper	Monthly	Operator	Make visual inspection of linkage, check for Proper operation
Combustion air	Monthly	Operator	All sources remain clean and open
Ignition System	Weekly	Operator	Make visual inspection, check flame signal Strength if meter-fitted (see Combustion Safety Controls)
Fuel Valves Pilot and main	Weekly	Operator	Open limit switch-make aural and visual check Check valve position indicators and check Fuel meters if so fitted
Pilot & main gas	Annually	Service Technician	Perform leakage tests – refer to valve manufacturer's instructions
Combustion safety controls Flame failure	Weekly	Operator	Close manual fuel supply for (1) pilot, (2) main fuel cock, and/or valve(s) check safety shutdown timing; log

Item	Frequency	Checked By	Remarks
Flame signal strength	Weekly	Operator	If flame signal meter installed, read and log; for both pilot and main flames, notify service organization if readings are very high, very low, or fluctuating; refer to flame safeguard manufacturer's instructions
Pilot turndown tests	as required/annually	Service Technician	Required after any adjustments to flame scanner mount or pilot burner; verify annually – refer to flame safeguard manufacturer's instructions.
Refractory hold in	As required/annually	Service Technician	See Pilot Turndown Tests
High limit safety control	Annually	Service Technician	Refer to heat exchanger manufacturer's instructions
Operating control	Annually	Service Technician	Refer to heat exchanger manufacturer's Instructions
Low draft, fan, air pressure, and damper	Monthly	Operator	Refer to this manual and control manufacturer's instructions
High & low gas pressure interlocks	Monthly	Operator	Refer to instructions in this manual
Fuel valve interlock switch	Annually	Service Technician	Refer to valve manufacturer's instructions
Purge switch	Annually	Service Technician	Refer to fuel/air control motor manufacturer's instructions
Low fire start interlock	Annually	Service Technician	Refer to fuel/air control motor manufacturer's instructions
Automatic changeover control (dual fuel)	At least annually	Service Technician	Under supervision of gas utility
Inspect burner components		Service Technician	Refer to this manual and control component Manufacturer's instructions
Check blower motor and blower wheel for cleanliness. Remove and clean as necessary	Annually	Service Technician	Remove and clean
Remove, inspect and clean gas pilot assembly	Annually	Service Technician	Remove and clean

Refer to heat exchanger manufacturer's instructions for general inspection procedures and for specific testing and inspection of all liquid level controls, pressure/temperature relief and other applicable items.

If you have any questions about the procedures listed above or questions relating to components or devices on your unit not specifically covered in the above, contact our Service Department at (620) 421-0480 for assistance.

17. BURNER START UP INFORMATION & TEST DATA

The following information shall be recorded for each burner start up:

Power Flame Model No. _____ Invoice No. _____ Serial No. _____

Installation Name _____ Start Up Date _____

Start Up Contractors Name _____ Phone _____

Name of Technician Performing Start Up _____

Type of Gas Natural LP Other _____

Gas Firing

Gas Pressure at Train Inlet Burner in Off Position _____ " W.C.	Flame signal Readings Pilot _____ Low Fire _____ High Fire _____	Stack Outlet Test Point Draft Low Fire _____ High Fire _____
Gas Pressure at Train Inlet Low Fire _____ High Fire _____	O ₂ Low Fire _____ High Fire _____	Net Stack Temperature Low Fire _____ High Fire _____
Gas Pressure at Firing Head Low Fire _____ High Fire _____	CO Low Fire _____ High Fire _____	Combustion Efficiency Low Fire _____ % High Fire _____ %
Gas Pressure at Pilot Test Tee _____	Input Rate BTU/HR Low Fire _____ High Fire _____	NOx Measured Low Fire _____ High Fire _____
Power Supply Volts _____ Ph _____ Hz _____ Control Circuit Volts _____ Blower Motor amps at high fire _____	Over Fire Draft Low Fire _____ High Fire _____	

Control Settings

General	Gas
Operating control cut out setting _____	Low gas pressure switch _____ in.
Operating control cut in setting _____	High gas pressure switch _____ in
Limit control cut out setting _____	
Limit control cut in setting _____	

Operation Checklist

Checked for Proper Operation of:	Yes	No		Yes	No
Low water cut off	()	()	Barometric damper	()	()
High water cut off	()	()	Boiler room combustion air and ventilation provisions correct	()	()
Flame safeguard control ignition failure	()	()			
Flame safeguard control main flame failure	()	()			
Burner air flow switch	()	()			
Induced draft fan controls	()	()	All gas lines checked for leaks	()	()
Over fire draft controls	()	()	Gas lines and controls properly vented	()	()
Fresh air damper end switch	()	()	Other system components (specify)	()	()
Notified _____	of the following system deficiencies: _____				

18. OWNER OPERATING INSTRUCTIONS

FOR YOUR SAFETY

If you smell gas:

1. Open windows
2. Do not touch electrical switches
3. Extinguish any open flame
4. Call you gas supplier immediately

Do not store or use gasoline or other flammable liquids and vapors in the vicinity of this or any other appliance.

IMPORTANT PRECAUTIONS

1. Never attempt to light burner with paper or other materials.
2. Never experiment with the burner.
3. Never change the fuel or air adjustments without consulting with the burner service company.
4. Never attempt to light the burner if combustion chamber contains any unburned fuel or gases.
5. Never throw waster paper, rags, garbage or other waster materials into the combustion chamber.
6. Never wash out heating equipment room without first covering the burner with waterproof material.

WARNING

Improper installation, adjustment, alteration, service or maintenance can cause injury or property damage. Refer to the burner manual. For assistance or additional information consult a qualified installer, service agency or the gas supplier.

START UP

Preparation for Start Up – All Fuels

1. Ensure that the system is in working order. If heat exchanger is a boiler, ensure that proper water level is available.
2. Set the burner control panel switch to the OFF position.

Combination Gas burner – set the fuel selector switch to the fuel to be burned.

3. Turn the thermostat or operating control down to its lowest setting.
4. Check fuses and replace as necessary.
5. Depress the flame safeguard programming control reset button.

Start Up

1. Manually open and close the main gas shut off cock, leak test cock and pilot cock to determine that they operate freely. Open all three cocks. (Reset low gas pressure switch if supplied).

2. Set the main power switch and burner panel control switch to the ON position. Wait 30 seconds and turn up thermostat or operating control to the desired setting.
3. The burner blower motor will start and after a suitable pre-purge period (this will vary with the type of flame safeguard control supplied – but will usually be minimum of 30 seconds, the burner pilot will light, after which the main flame will be established.
4. If the system does not respond properly, contact your qualified burner service company.

EXTENDED SHUT DOWN

1. Place main power switch and burner control panel switch in the OFF position.
2. Close all gas valves.
3. Cover burner to protect it from dust and dampness.

MAINTENANCE

1. See Maintenance section in burner manual for suggestions on periodic maintenance and service.

