

# Power Flame Incorporated



***Nova® Induced FGR  
Low NOx Combustion System  
Type J, C, CMAX, and AC Burners***

## Installation and Operation Manual

**Power Flame Incorporated**  
*The Power to Manage Energy*

2001 South 21<sup>st</sup> Street, Parsons, KS 67357  
Telephone: 620-421-0480 FAX: 620-421-0948  
Product Support: 620-820-8301  
Website: <http://www.powerflame.com>  
e-mail: [CSD@powerflame.com](mailto:CSD@powerflame.com)

**Copyright 2009 Power Flame Incorporated**

# FOR YOUR SAFETY

If you smell gas:

1. Open windows.
2. Do not touch electrical switches.
3. Extinguish any open flame.
4. Call your gas supplier immediately.

Do not store or use gasoline or other flammable liquids and vapors in the vicinity of this or any other appliance.

## WARNING

Improper installation, adjustment, alteration, service or maintenance can cause injury or property damage. Refer to this manual. For assistance or additional information consult a qualified installer, service agency or the gas supplier.

## NOTICE

Effective 4/1/94 Underwriters Laboratories require that all gas burners firing at inputs of 2,500 MBH and under be supplied with two gas safety valves or one gas valve with proof of closure (Valve seal over travel). The photos in this manual may not depict these specific components. ALL U.L. listed products shipped after 4/1/94 will comply with the U.L. requirements.

## IMPORTANT

**THE INSTALLATION OF A BURNER SHALL BE IN ACCORDANCE WITH THE REQUIREMENTS OF AUTHORITIES HAVING JURISDICTION.**

**THESE INSTRUCTIONS SHALL REMAIN WITH THE EQUIPMENT FOR SERVICING.**

**ON OPENING THE OIL SUPPLY VALVE(S) CHECK FOR LEAKS ON THE SUPPLY LINE(S) AND COMPONENTS.**

**DO NOT TAMPER WITH THE UNIT OR CONTROLS, CALL YOUR SERVICE PERSON.**

**REGULAR MAINTENANCE SHALL BE PROVIDED TO THE UNIT BY SERVICE PERSONNEL AT LEAST ONCE A YEAR.**

<b>1. PRINCIPLES OF OPERATION</b> .....	<b>1</b>
<b>1.1 INTRODUCTION</b> .....	<b>1</b>
<b>1.2 BURNER DESCRIPTION</b> .....	<b>2</b>
<b>1.3 THEORY OF OPERATION</b> .....	<b>4</b>
<b>1.4 TEST RESULTS</b> .....	<b>5</b>
<b>2. INSTALLATION AND START UP INSTRUCTIONS</b> .....	<b>6</b>
<b>2.1 INSTALLATION</b> .....	<b>6</b>
<b>2.1.1 IFGR Low NOx ADAPTER</b> .....	<b>6</b>
<b>2.1.2 Induced Flue Gas Recirculation Piping</b> .....	<b>6</b>
<b>2.1.3 Induced Flue Gas Recirculation Purge Assembly</b> .....	<b>6</b>
<b>2.1.4 Fuel Piping</b> .....	<b>7</b>
<b>2.1.5 Wiring</b> .....	<b>7</b>
<b>2.2 BURNER START-UP</b> .....	<b>7</b>
<b>2.2.6 Instruments Required</b> .....	<b>7</b>
<b>2.2.7 Varicam Reference Information</b> .....	<b>7</b>
<b>2.2.8 Initial Adjustments</b> .....	<b>11</b>
<b>2.2.9 Start-Up</b> .....	<b>11</b>
<b>2.2.10 IFGR Modulating Damper Setting</b> .....	<b>11</b>
<b>2.2.11 Determining Percent IFGR</b> .....	<b>12</b>
<b>2.2.12 Flame Appearance</b> .....	<b>13</b>
<b>2.2.13 Oil Firing</b> .....	<b>13</b>
<b>2.2.14 NOx Correction Factor</b> .....	<b>14</b>
<b>2.2.15 Combustion Efficiency</b> .....	<b>14</b>

# 1. PRINCIPLES OF OPERATION

## 1.1 Introduction

The NOVA Induced Flue Gas Recirculation (IFGR) System was developed as a compliment to the Power Flame Forced FGR and Staged Fuel NOVA systems in order to encompass a broader spectrum of low NOx emissions demands. These systems have been successfully proven in field applications on both watertube and firetube applications and are proven to meet or exceed stringent NOx emissions guidelines. Testing and field operations have been performed using natural gas, digester gas, and light oil. NOx reductions in excess of 60% have been obtained firing natural gas and reductions in excess of 40% with No. 2 fuel oil. The NOVA IFGR Combustion System is UL listed as "Emissions Reduction Equipment" and is available as a retrofit for existing standard burner installations (natural gas and light oil).

The NOVA IFGR System incorporates Induced Flue Gas Recirculation technology to reduce the level of NOx emissions. The unique feature of the NOVA IFGR System is that the IFGR inlet assembly is adapted directly to Power Flame's standard gas or gas/oil burner.

Unlike most low NOx burner designs which incorporate complex control schemes, the NOVA System is designed for easy installation with simple start-up and control requirements. The IFGR control damper is driven from the main fuel air jackshaft control system and requires a one-time adjustment at initial commissioning. As an option, parallel positioning technology can be purchased for precise flue gas metering and NOx control. Call our Customer Service Department for details.

The NOVA IFGR System is available for heat input requirements ranging up to 92.0 million Btu/hr. Either Power Flame Standard J, C, CMAX or AC Series burners can be utilized in conjunction with the NOVA IFGR System.

## 1.2 Burner Description

The NOVA IFGR System consists of three basic components (as depicted in Figure 1):

- Standard Power Flame Gas or Gas/Oil burner
- NOVA IFGR Low NOx adapter with modulating damper
- IFGR Purge Assembly (shut-off damper and motor)

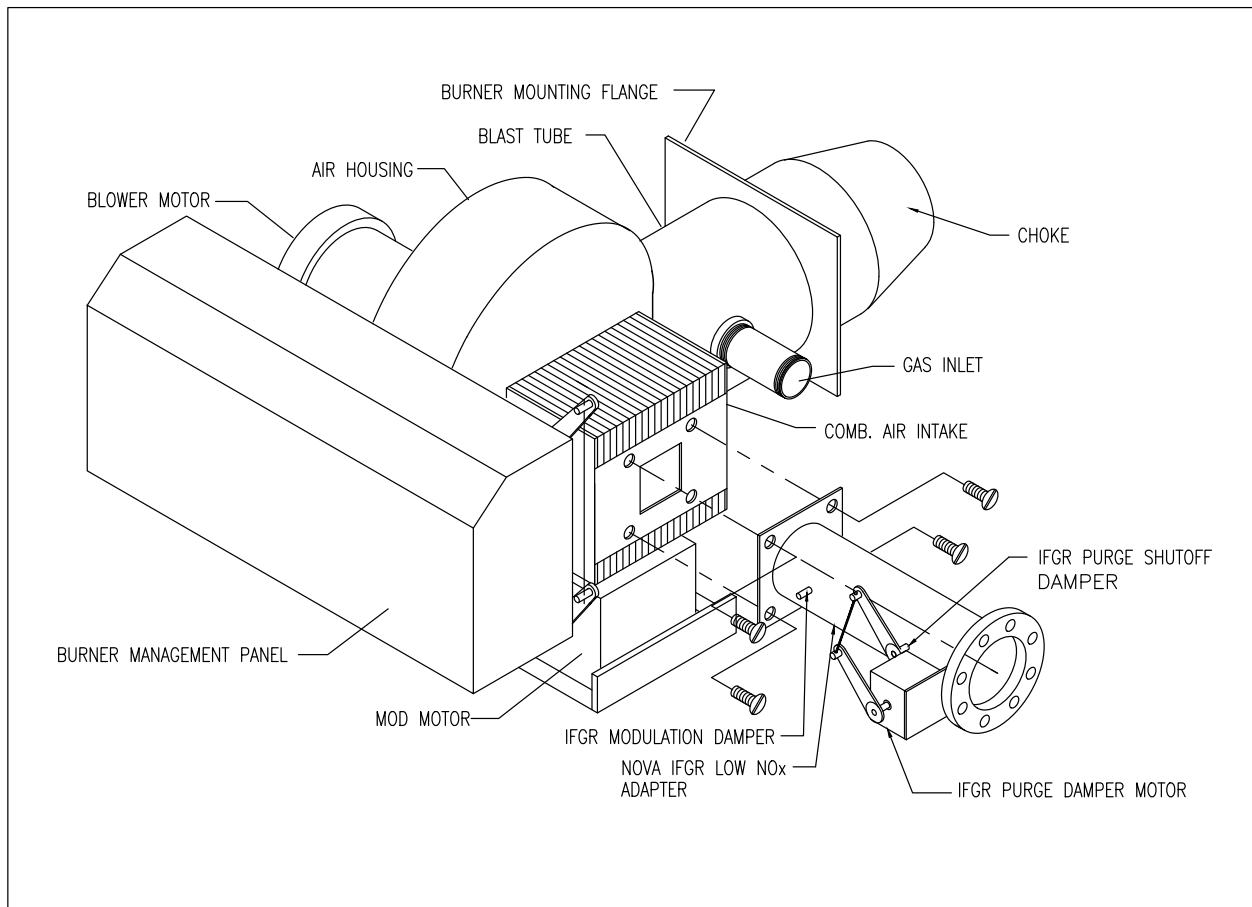

Figure 1: Nova IFGR Combustion System adapter arrangement.

Please note that the arrangement shown in Figure 1 is typical of all LNIC(R), LNIAC(R), LNIJ(R), and LNICM(R) burners. The Figure does not show the proprietary Varicam® metering system which can be purchased as an option for more precise control of fuel, air and IFGR ratios.

The IFGR assembly is designed to mix the IFGR and burner combustion air before delivery to the primary flame zone.

This assembly attaches to the standard air inlet assembly for C(R), AC(R), and CM(R) burners and to an extended air inlet assembly for "JA(R)" burners. Burner mounting to the boiler or heat exchanger is not affected.

The standard IFGR assembly includes the IFGR modulating damper which is driven with mechanical linkage from the standard fuel/air control system and a IFGR purge assembly which ensures that IFGR is not introduced during purge or ignition cycles.

The standard IFGR assembly includes a mounting flange to connect IFGR piping. Minimum recommended IFGR pipe sizes are listed in **Table 1 and 2**. Power Flame does not supply IFGR piping.

The Power Flame NOVA IFGR burner system is rated at firing capacities different from its standard PFI burner counterparts. These ratings, based on reduced combustion air capacities to accommodate the recirculated flue gas, are as follows for a typical 30 ppm system:

<b>J(R)</b>		
<b>Model</b>	<b>Firing Rate MBH</b>	<b>Furnace Pressure "WC</b>
<i>LNIJ15A-10</i>	600	0.2
<i>LNIJ30A-10</i>	915	0.2
<i>LNIJ30A-12</i>	1,075	0.2
<i>LNIJ50A-15</i>	1,870	0.2

<b>AC(R) (G, O and GO)</b>		
<b>Model</b>	<b>Firing Rate MBH</b>	<b>Furnace Pressure "WC</b>
<i>LNIAC3-20</i>	3,780	0.2
<i>LNIAC3-25</i>	3,780	0.2
<i>LNIAC3-25B</i>	4,025	0.2
<i>LNIAC4-25</i>	4,825	0.2
<i>LNIAC4-30</i>	6,000	0.2
<i>LNIAC5-30B</i>	8,000	0.2
<i>LNIAC6-30</i>	10,872	0.2
<i>LNIAC7-30</i>	12,780	0.2
<i>LNIAC8-30</i>	13,950	0.2

<b>C(R) (G, O and GO)</b>		
<b>Model</b>	<b>Firing Rate MBH</b>	<b>Furnace Pressure "WC</b>
LNIC1-10	835	0.2
LNIC1-12	1,160	0.2
LNIC2-15	1,870	0.2
LNIC2-20A	2,125	0.2
LNIC2-20B	2,620	0.2
LNIC3-20	3,570	0.2
LNIC3-25	4,010	0.2
LNIC3-25B	4,470	0.2
LNIC4-25	5,360	0.2
LNIC4-30	6,670	0.2
LNIC5-30	8,925	0.2
LNIC5-30B	8,925	0.2
LNIC6-30	12,080	0.2
LNIC7-30	14,200	0.2
LNIC8-30	15,500	0.2

<b>CM(R) (G, O and GO)</b>		
<b>Model</b>	<b>Firing Rate MBH</b>	<b>Furnace Pressure "WC</b>
LNICM9-30	11,800	1.0
LNICM9A-30	14,800	1.0
LNICM9B-30	17,500	1.0
LNICM10-30	19,948	2.5
LNICM10A-30	22,600	2.5
LNICM10B-30	25,700	2.5
LNICM10C-30	31,000	2.5
LNICM11-30	39,100	4.0
LNICM11A-30	45,050	4.0
LNICM12-40	51,000	7.0
LNICM12A-40	54,300	7.0
LNICM13-40	75,600	7.0
LNICM14-40	92,400	7.0

### 1.3 Theory of Operation

The standard Power Flame burner provides the primary combustion components for the NOVA IFGR System. The NOVA IFGR adapter and controls provide the flue gas metering equipment necessary to reduce NOx emissions.

The combustion air, thoroughly mixed with a percentage of Flue Gas, is introduced to the combustion zone through the standard burner and burner head assembly. This increased "air side" mass flow for a given heat release provides results very similar to lean combustion but, with less added oxygen to combine with nitrogen to form NOx. The rate of thermal NOx formation is primarily temperature dependant, hence lower resultant NOx formation is achieved by the heat absorption effect of the increased mass flow of combustion air/IFGR mixture in the combustion zone. This increased mass flow results in greater turbulence for the combustion process generally providing shorter, more compact flame envelopes.

Note that the added mass flow through the system results in a system pressure drop increase. Typical total combustion chamber static pressure increases of 20 to 30% can be expected on most installations when operating at the rated capacity of the heat exchanger.

## **1.4 Test Results**

Extensive testing of the standard Power Flame burner and the NOVA IFGR System have been performed on the following boilers:

- Ajax Watertube Model WGFD-1500 through WGFD-3500
- Bryan Steam Watertube Model AB-90 through AB-250
- Bryan Steam Watertube Model RV-200 through RV-800
- Bryan Steam Watertube Model RW-850 through RW-1260
- Bryan Steam Watertube Model RW-1500 through RW-2100
- Burnham Model 3P & 4P Scotch Marine Boilers
- Burnham E Series boilers
- Burnham Firebox Model 4F-63 through 4F-675A
- Cleaver Brooks Model FLX-150 through FLX-900
- Hurst Series 200-500 and Euro Boilers
- Hurst Firebox Series 45 Model 13.4 HP through 250 HP
- Hurst Firebox Series 100 Model 7.4 HP through 265 HP
- Hurst Boiler Series 4VT Model 20 HP through 100 HP
- Industrial Boiler Model 3PV-10 HP through 3PV-60 HP
- Kewanee Firebox Model V15 through V300
- RECO Vertical Water Heater Model R14 through R150
- Rite Watertube Boiler Model 48 (S or W) through 1250 (S or W)
- Superior Apache 50 and 100 HP boilers
- UBW Watertube Model BF-50 through BF-300
- Unilux Watertube Model Z-25 through Z-1200 (W or F)



## 2. INSTALLATION AND START UP INSTRUCTIONS

The NOVA IFGR low NOx Burner System is designed and packaged to operate with Power Flame's standard J, C, CMAX or AC burners. The following information is intended to supplement instructions provided in the J, C and CMAX Manuals.

### 2.1 Installation

#### 2.1.1 IFGR Low NOx adapter

The IFGR low NOx adapter is pre-mounted to the Power Flame burner. Burner mounting details are as provided in the standard J, C, AC, and CMAX burner manuals with no special mounting adapters required.

#### 2.1.2 Induced Flue Gas Recirculation Piping

Induced flue gas recirculation (IFGR) piping is not provided by Power Flame. Induced flue gas pipe sizing recommendations are included in **Table 1 and 2**. The IFGR concept is shown schematically in **Figure 2**.

Install the IFGR piping from the stack (preferred method), or last pass smoke box, to the burner IFGR connecting flange. If the takeoff is from the stack, it should be upstream of any stack damper or barometric damper. If a barometric damper is used, care must be taken to ensure that fresh air infiltration into the IFGR system does not occur. It is recommended that the IFGR pipe extends to the center of the stack and includes a 45° miter cut facing down into the stack flue gas flow (**see Table 1 and 2**). Seamless carbon steel pipe or tubing is recommended for the IFGR pipe.

The IFGR piping should be routed to minimize pipe length and number of fittings. In higher draft applications, increased pipe sizes from that recommended in **Table 1 and 2** may be required.

Induced flue gas piping between the stack and burner should be evaluated for insulation requirements based on personnel protection requirements, allowable site heat dissipation specifications (if indoors), and applicable codes. Lower flue gas temperatures enhance IFGR operation. Caution must be taken not to operate at extended periods or larger number of cycles with IFGR temperatures below 250° F as to prevent condensation and excessive corrosion.

#### 2.1.3 Induced Flue Gas Recirculation Purge Assembly

The Induced Flue Gas Recirculation (IFGR) adapter includes an isolation damper assembly to ensure that IFGR is not introduced into the burner during pre-purge, ignition, initial main fuel, or post purge cycles. The shutoff damper is driven by a two position motor which includes an end position switch to prove that the IFGR is OFF during restricted cycles.

The IFGR shutoff damper motor actuation circuit includes a time delay to allow main flame establishment before introducing IFGR to the burner. This time delay (typically 2 minutes) allows for burner flame stabilization and prevents excessively cool IFGR flow in the system which may cause flue gas condensation.

The time delay is adjustable from 1 to 1023 seconds. Each switch on the device is marked with its associated time delay. Time delay adjustment is accomplished by switching the appropriate switch ON to obtain the desired cumulative delay set point.

#### **2.1.4 Fuel Piping**

Install gas supply piping and gas train components per the gas piping diagram supplied with the burner. Refer to the burners manuals for installation and testing information. If the burner is a combination gas/oil type, install supply and return oil piping, per the manufacturer's recommendations, adhering to all governing local and state codes.

#### **2.1.5 Wiring**

Wire gas train components and interconnecting wiring per the wiring diagram supplied with the burner. IFGR wiring connections are integral to the burner and are pre-wired at the factory.

## **2.2 Burner Start-Up**

#### **2.2.6 Instruments Required**

It is strongly recommended that electronic flue gas analysis and fuel flow metering equipment be utilized during start-up to provide measured outputs of the following:

- Fuel Flow
- O<sub>2</sub> (excess oxygen)
- CO (carbon monoxide)
- NOx (oxides of nitrogen)
- Stack Temperature

#### **2.2.7 Varicam Reference Information**

If your system is equipped with the Power Flame Cam Actuated Metering System(s) - Varicam® - Refer to the burners manuals, for start-up and adjustment procedures. The NOVA IFGR Low NOx System requires limited additional adjustment beyond that of a standard Power Flame Burner.

THIS DOCUMENT CONTAINS CONFIDENTIAL AND PROPRIETARY INFORMATION OF PFI AND IS SUBJECT TO CHANGE WITHOUT PRIOR NOTIFICATION.

PIPE DIAMETER		MINIMUM PIPE SIZE - SCHEDULE 10 STEEL PIPE										EQUIVALENT LINEAL FEET FOR SCHEDULE 10 PIPE FITTINGS											
		MAXIMUM FEET FROM BURNER TO BOILER STACK										NOMINAL PIPE SIZE											
FIRING RATE (MBH)		20'	30'	40'	50'	75'	100'	150'	200'	6"	8"	10"	12"	14"	16"	18"	45° ELBOW	90° ELBOW	LG R.90 ELBOW				
10,000	6"	6"	8"	8"	8"	8"	8"	10"	10"	10"	10"	10"	10"	10"	10"	10"	8.0'	10.7'	13.3'	16.0'	18.7'	21.3'	24.0'
15,000	8"	8"	8"	8"	8"	10"	10"	10"	10"	10"	10"	10"	10"	10"	10"	10"	15.0'	20.0'	25.0'	30.0'	35.0'	40.0'	45.0'
20,000	8"	8"	10"	10"	10"	10"	10"	10"	10"	10"	10"	10"	10"	10"	10"	10"	10.0'	13.5'	17.0'	20.0'	23.5'	26.7'	30.0'
25,000	8"	10"	10"	10"	10"	12"	12"	12"	12"	12"	12"	12"	12"	12"	12"	12"	10.0'	13.5'	17.0'	20.0'	23.5'	26.7'	30.0'
30,000	10"	10"	10"	10"	10"	12"	12"	12"	12"	12"	12"	12"	12"	12"	12"	12"	10.0'	13.5'	17.0'	20.0'	23.5'	26.7'	30.0'
35,000	10"	10"	10"	10"	10"	12"	12"	12"	12"	12"	12"	12"	12"	12"	12"	12"	10.0'	13.5'	17.0'	20.0'	23.5'	26.7'	30.0'
40,000	10"	10"	12"	12"	12"	12"	12"	12"	12"	12"	12"	12"	12"	12"	12"	12"	10.0'	13.5'	17.0'	20.0'	23.5'	26.7'	30.0'
50,000	12"	12"	12"	12"	12"	14"	14"	14"	14"	14"	14"	14"	14"	14"	14"	14"	10.0'	13.5'	17.0'	20.0'	23.5'	26.7'	30.0'
60,000	12"	12"	12"	12"	12"	14"	14"	14"	14"	14"	14"	14"	14"	14"	14"	14"	10.0'	13.5'	17.0'	20.0'	23.5'	26.7'	30.0'
70,000	12"	14"	14"	14"	14"	16"	16"	16"	16"	16"	16"	16"	16"	16"	16"	16"	10.0'	13.5'	17.0'	20.0'	23.5'	26.7'	30.0'
80,000	14"	14"	14"	14"	14"	16"	16"	16"	16"	16"	16"	16"	16"	16"	16"	16"	10.0'	13.5'	17.0'	20.0'	23.5'	26.7'	30.0'
90,000	14"	14"	16"	16"	16"	18"	18"	18"	18"	18"	18"	18"	18"	18"	18"	18"	10.0'	13.5'	17.0'	20.0'	23.5'	26.7'	30.0'
100,000	14"	16"	16"	16"	16"	18"	18"	20"	20"	20"	20"	20"	20"	20"	20"	20"	10.0'	13.5'	17.0'	20.0'	23.5'	26.7'	30.0'

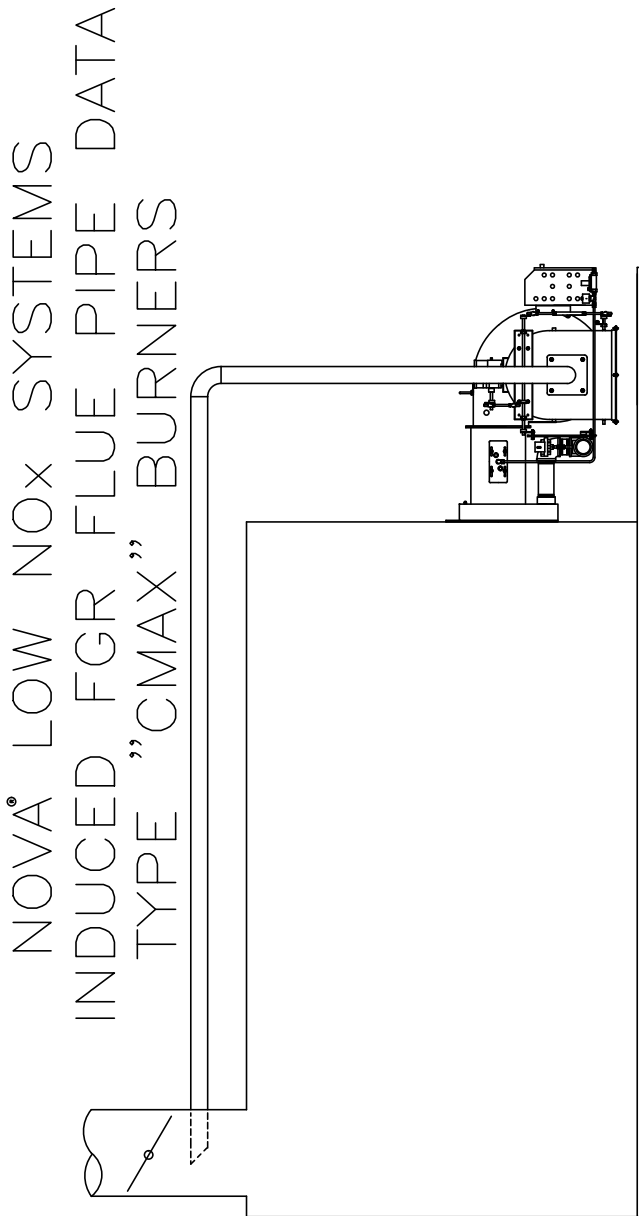

NOTE 1: FIELD INSULATE ALL FLUE GAS PIPES AND FITTINGS FOR PERSONNEL PROTECTION, AND UNDESIRED HEAT LOSS/HEAT GAIN.  
 NOTE 2: SIZES ARE BASED ON FGR TEMPERATURES OF LESS THAN 550° F AND ON DRAFT CONDITIONS AT THE BREACH OF LESS THAN .1" W.C.DRAFT (-.1"W.C. GAUGE). CONSULT POWERFLAME IF CONDITIONS OUTSIDE OF THESE PARAMETERS ARE ENCOUNTERED.  
 NOTE 3: SIZES ARE BASED ON THE MAXIMUM CAPACITY OF THE BURNER AND 15% FGR. BURNERS FIRING LESS THAN THEIR MAXIMUM CAPACITY OR USING LESS THAN 15% FGR MAY BE ABLE TO USE A SMALLER PIPE SIZE. CONSULT FACTORY TO DETERMINE IF A SMALLER PIPE SIZE CAN BE UTILIZED.

**Power Flame Incorporated**  
 2001 SOUTH 21st STREET PARSONS, KANSAS 67357  
 PHONE (620) 421-0480 FAX (620) 421-0948



ENGINEERING SPEC.  
 AND DATA SHEET

Table 1: IFGR piping data for CMAX burner

NOVA® LOW NOx SYSTEMS  
INDUCED FGR FLUE PIPE DATA  
TYPE "J", "C" & "AC" BURNERS

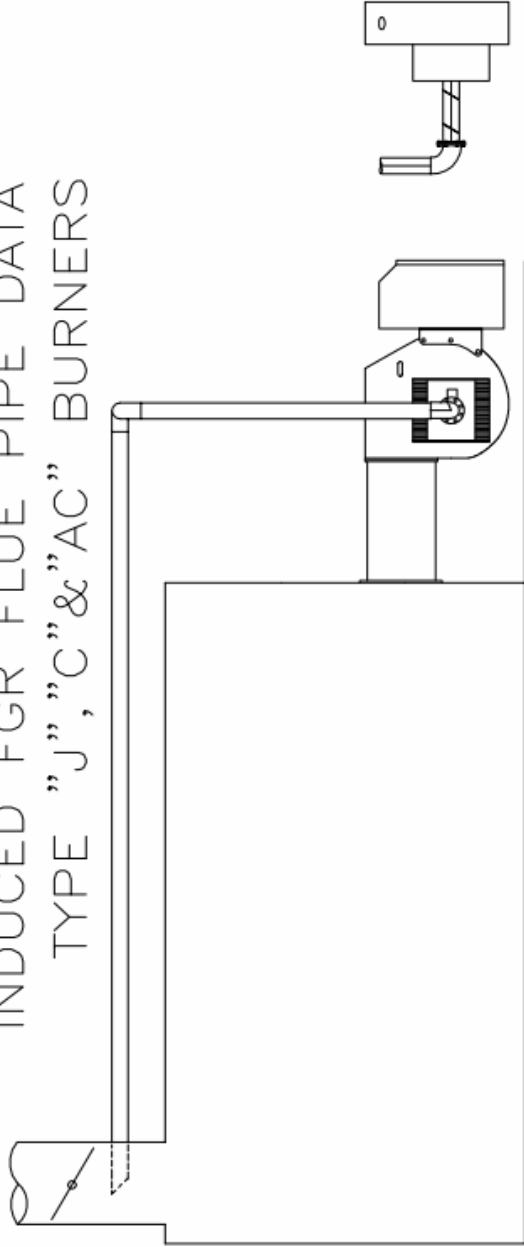

BURNER MODEL	MINIMUM PIPE SIZE - SCHEDULE TO STEEL PIPE								EQUIVALENT LINEAL FEET FOR SCHEDULE TO PIPE FITTINGS							
	20'	30'	40'	50'	75'	100'	150'	200'	PIPE FITTINGS	3"	4"	6"	8"	10"	12"	
LNJ15-A	3"	3"	3"	3"	3"	3"	4"	4"	45° ELBOW	4.0'	5.3'	8.0'	10.7'	13.3'	16.0'	
LNJ30-A	3"	3"	3"	4"	4"	4"	4"	4"	90° ELBOW	7.5'	10.0'	15.0'	20.0'	25.0'	30.0'	
LNJ50-A	4"	4"	4"	4"	6"	6"	6"	6"	LG. R.90 ELBOW	5.0'	7.0'	10.0'	13.5'	17.0'	20.0'	
LNIC1-G(GO)-10	3"	3"	3"	3"	4"	4"	4"	4"								
LNIC1-G(GO)-12	3"	3"	3"	4"	4"	4"	4"	4"								
LNIC2-G(GO)-15	4"	4"	4"	4"	6"	6"	6"	6"								
LNIC2-G(GO)-20A	4"	4"	4"	4"	6"	6"	6"	6"								
LNIC2-G(GO)-20B	4"	4"	4"	6"	6"	6"	6"	6"								
LNIC3-G(GO)-20	4"	4"	6"	6"	6"	6"	6"	6"								
LNIC3-G(GO)-25	6"	6"	6"	6"	6"	6"	6"	6"								
LNIC3-G(GO)-25B	6"	6"	6"	6"	6"	6"	6"	6"								
LNIC4-G(GO)-25	6"	6"	6"	6"	8"	8"	8"	8"								
LNIC4-G(GO)-30	6"	6"	6"	6"	8"	8"	8"	8"								
LNIC5-G(GO)-30	6"	6"	6"	8"	8"	8"	10"	10"								
LNIC5-G(GO)-30B	6"	6"	6"	8"	8"	8"	10"	10"								
LNIC6-G(GO)-30	8"	8"	8"	8"	10"	10"	10"	12"								
LNIC7-G(GO)-30	8"	8"	8"	8"	10"	10"	10"	12"								
LNIC8-G(GO)-30	8"	8"	8"	10"	10"	10"	12"	12"								

NOTE 1: FIELD INSULATE ALL FLUE GAS PIPES AND FITTINGS FOR PERSONNEL PROTECTION, AND UNDESIRABLE HEAT LOSS/HEAT GAIN.

NOTE 2: SIZES ARE BASED ON FGR TEMPERATURES OF LESS THAN 550°F AND ON DRAFT CONDITIONS AT THE BREACH OF LESS THAN .1" W.C. DRAFT (-1" W.C. GAUGE). CONSULT POWERFLAME IF CONDITIONS OUTSIDE OF THESE PARAMETERS ARE ENCOUNTERED.

NOTE 3: DIMENSIONS CAN VARY WITH OPTIONAL EQUIPMENT AND SYSTEMS ARRANGEMENTS. FINAL PIPING CONNECTIONS SHOULD BE DETERMINED AFTER INSTALLATION.

NOTE 4: SIZES ARE BASED ON THE MAXIMUM CAPACITY OF THE BURNER AND 15% FGR. BURNERS FIRING LESS THAN THEIR MAXIMUM CAPACITY OR USING LESS THAN 15% FGR MAY BE ABLE TO USE A SMALLER PIPE SIZE. CONSULT FACTORY TO DETERMINE IF A SMALLER PIPE SIZE CAN BE UTILIZED.

**Power Flame Incorporated**  
2001 SOUTH 21st STREET      PHONE (620) 421-0480  
PARSONS, KANSAS 67357      FAX (620) 421-0948



ENGINEERING SPEC.  
AND DATA SHEET

Table 2: IFGR piping data for C, AC, and J burner

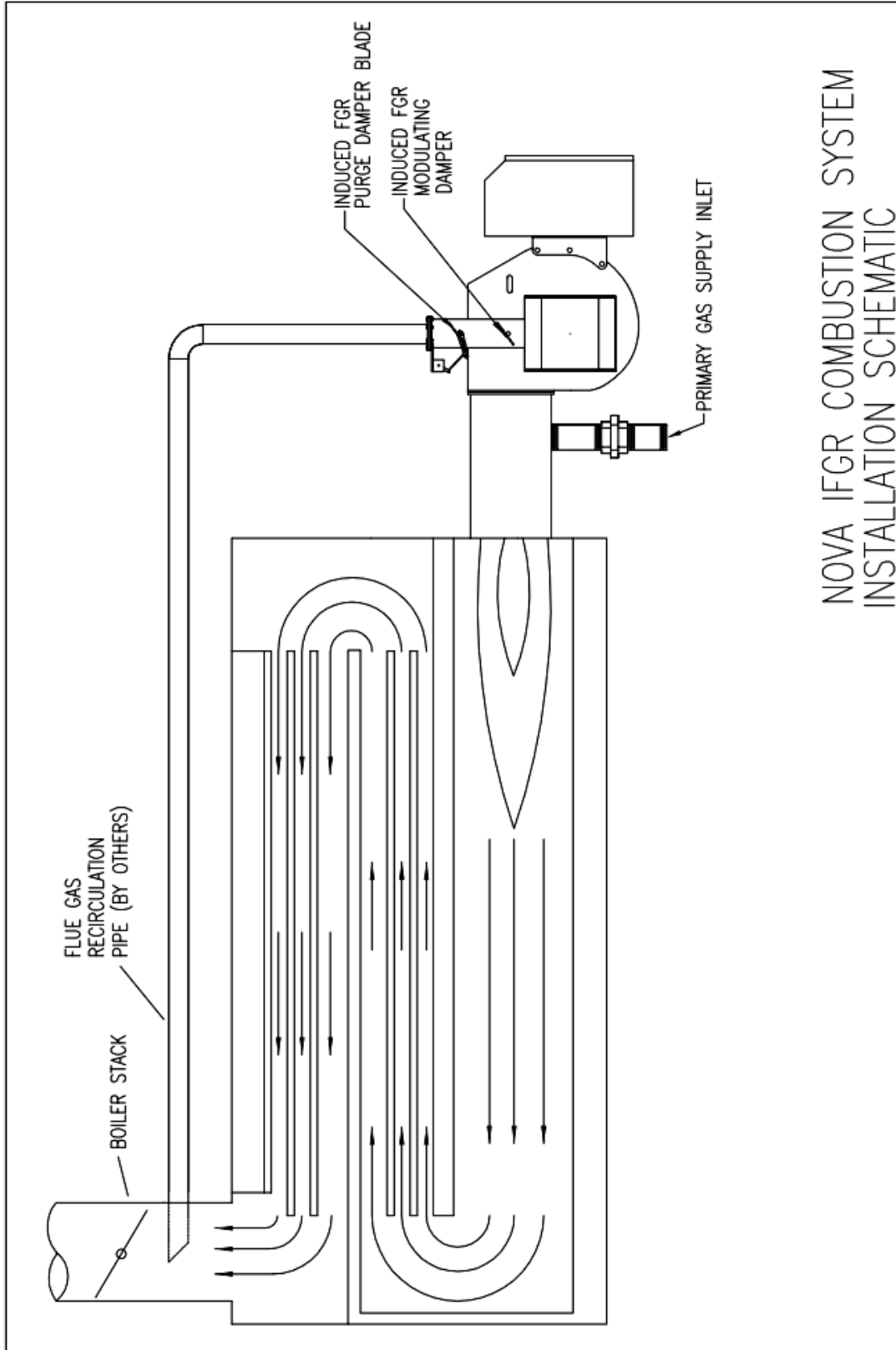

Figure 2: IFGR installation schematic

### 2.2.8 *Initial Adjustments IFGR modulating damper*

For initial system commissioning it is recommended that the IFGR modulating damper be disconnected from the fuel/air control system and locked in the closed position.

### 2.2.9 *Start-Up*

With the initial adjustment complete, general start-up procedures are as described in the burners manuals. When initially adjusting the fuel/air ratio over the desired firing range, the excess O<sub>2</sub> in the boiler stack flue gas should be increased by 1 to 1½ percent over standard burner set-up (for 20 ppm systems, 1½ to 3 percent over standard burner setup). Subsequent introduction of normally expected amounts of recirculated flue gas will typically decrease the excess O<sub>2</sub> percent to standard burner operating levels.

During initial and subsequent cold boiler start-ups, the boiler should be warmed up slowly, per the boiler manufacturer's recommendations, to prevent potential damage to any uncured and/or wet refractories that may be present, as well as to avoid thermal shock and unwanted stresses.

### 2.2.10 *IFGR Modulating Damper Setting*

After the burner fuel/air ratios have been set and the unit sufficiently warm, the IFGR modulating damper can be set. Ensure that the burner is at minimum input (low fire), that the IFGR delay time has expired, and that the IFGR Shutoff Purge Damper is open to IFGR. Begin with a minimal IFGR modulating damper opening.

Monitor the flue NO<sub>x</sub> content exiting the boiler stack. Slowly, in 5° increments, open the IFGR modulating damper. Wait several minutes after each adjustment to ensure that sufficient time has elapsed for the flue analyzer to respond to the change. When the NO<sub>x</sub> readings are below those required by job specifications, connect the IFGR modulating damper linkage ensuring that the damper remains at the last incremental adjustment point.

**NOTE: during and after each adjustment, monitor the boiler and the burner for combustion stability and check O<sub>2</sub> and CO content in the flue gas. If excessive combustion rumble is present or if CO levels exceed acceptable limits, reduce the IFGR control damper to the previous position.**

After the IFGR modulating damper has been set and connected to the mechanical drive linkage the firing rate can be increased in 10% increments (for modulating units) to confirm emissions operation over the entire firing range. Typical IFGR modulating damper settings will be 10 to 15° open at low fire and 60 to 90° open at high fire. Different settings are acceptable based on the systems emissions performance. Drive linkage and arms can be appropriately adjusted if the IFGR modulating damper opening rates need to be speeded up or retarded.

As noted previously, the excess O<sub>2</sub> content in the flue gas will typically decrease 1 to 1½% for a 30 ppm

system, or 1½ to 3% for a 20 ppm system from non-IFGR operational settings when expected IFGR amounts are introduced to the burner.

**NOTE: Combustion problems are generally caused by too much IFGR volumetric flow. If stack flue gas pressures are high, typically above +0.1" W.C., a reducing orifice may be required in the IFGR piping to restrict excessive flow. Consult the Power Flame Factory if this circumstance is encountered.**

**NOTE: Typical IFGR percentages range between 5 and 15% on 30 ppm systems and 15 and 30% on 20 ppm systems. Insufficient IFGR results in higher NOx emissions, while excessive IFGR flow can result in combustion instability and higher-than-normal CO.**

### 2.2.11 Determining Percent IFGR

There are two commonly used methods for determining the IFGR volumetric percent flow rate (% IFGR).

The first method requires the use of an oxygen analyzer to measure the excess oxygen level in the flue gas and the oxygen level of the combustion air plus IFGR in the burner air housing. The second reading (burner air housing) may be obtained by inserting the analyzer probe through the burner observation port or by drilling a small hole and inserting the probe near the discharge of the air housing. The small hole can be plugged with a sheet metal screw. After taking the two readings follow the instructions on **Table 3** to determine the % IFGR.

The second method for determining % IFGR involves taking temperature measurements of the ambient air, flue gas and combustion air/IFGR mixture. Using thermometers or temperature probes, take the required readings to calculate the temperature ratio  $\phi$ :

$$\phi = \frac{T_{mix} - T_{amb}}{T_{FGR} - T_{mix}}$$

$T_{mix}$  = Temperature of combustion Air/IFGR Mix (inside air housing)

$T_{amb}$  = Ambient Air Temperature

$T_{FGR}$  = Flue Gas Temperature (inside IFGR duct)

Based upon the temperature ratio the % IFGR can be calculated by:

$$\%_{IFGR} = \frac{1800 \cdot \phi}{1 + 18 \cdot (1 + \phi)}$$

To simplify this calculation we have provided a graph (**Figure 3**) where the temperature ratio is plotted against the % IFGR. After calculating the temperature ratio and locating that value on the X-Axis, move vertically to the plotted curve then read the % IFGR value across the graph on the Y-Axis. Excess air (%)

O<sub>2</sub>) in the stack or fuel type have very little effect on the calculated % IFGR. Software for this calculation can be provided by Power Flame through our Customer Service Department (620-421-0480 or [CSD@powerflame.com](mailto:CSD@powerflame.com)).

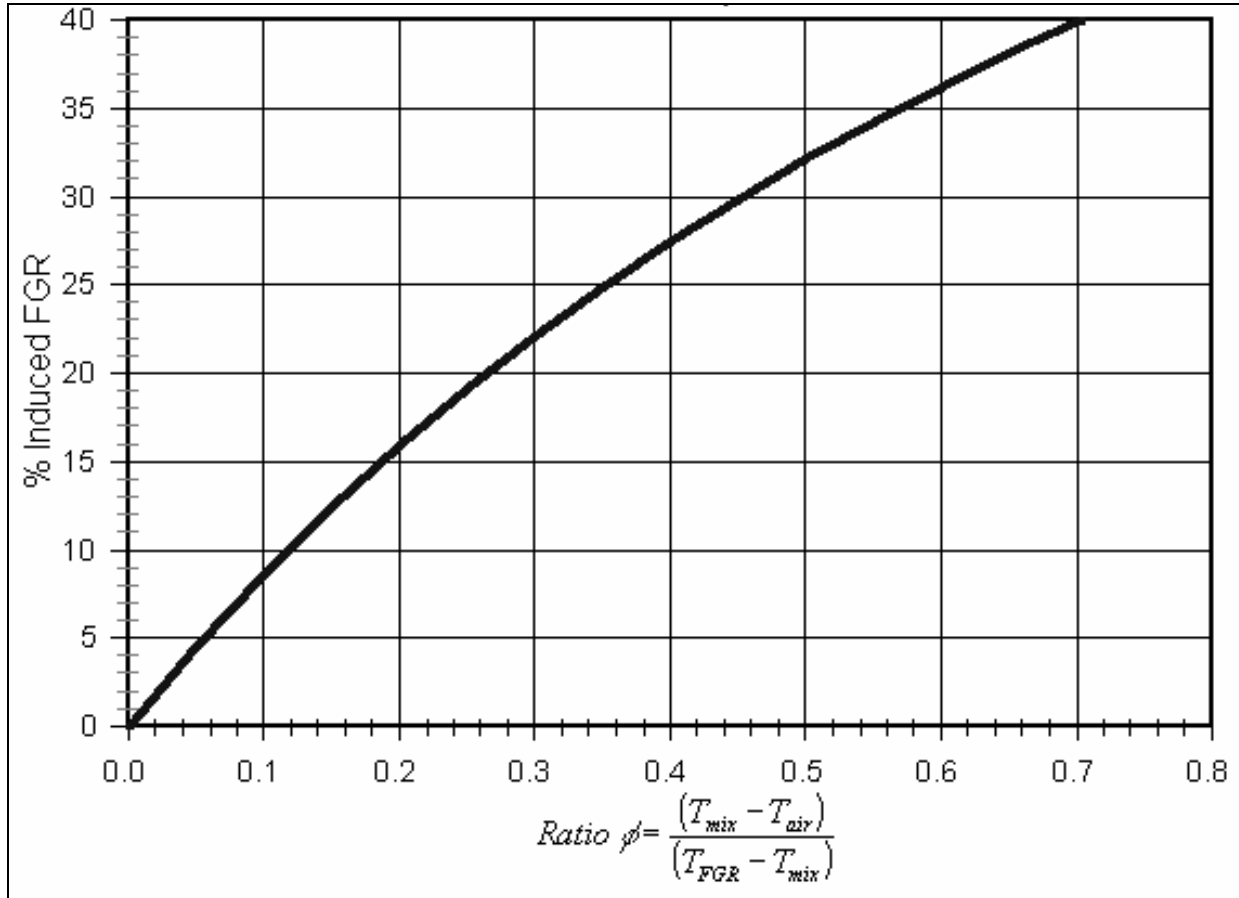

Figure 3: Percent IFGR as a function of the temperature ratio

### 2.2.12 Flame Appearance

The NOVA IFGR low NOx flame characteristics will differ from that of a standard gas burner. The additional air-side volumetric flow, caused by the addition of recirculated flue gas, results in greater turbulence to promote mixing. This results typically in smaller more compact flames than a standard burner. The flame may also appear "hazy" due to the effects of IFGR lowering flame temperature.

### 2.2.13 Oil Firing

Oil start-up of a gas/oil low NOx burner is identical to that of a standard C, AC or CMAX burner with the addition of IFGR adjustments as discussed in Section 2.2, above. Refer to burners manuals for start-up instructions. Care must be taken as to not induce excessive amounts of FGR for good, stable oil firing.



### 2.2.14 NOx Correction Factor

Most codes and standards regarding NOx emissions are based on a PPM level corrected to 3% O<sub>2</sub>. To correct NOx to a specified O<sub>2</sub> level, use the following formula:

$$NO_x(\text{corrected}) = \frac{17.9}{20.9 - O_2(\text{measured})} \cdot NO_x(\text{measured})$$

### 2.2.15 Combustion Efficiency

Figure 4 shows combustion efficiency as a function of net stack temperature and O<sub>2</sub> in the stack for natural gas. Net stack temperature is the difference between the measured stack temperature and ambient temperature. This graph does not include radiation and convection losses from the boiler or heat exchanger.

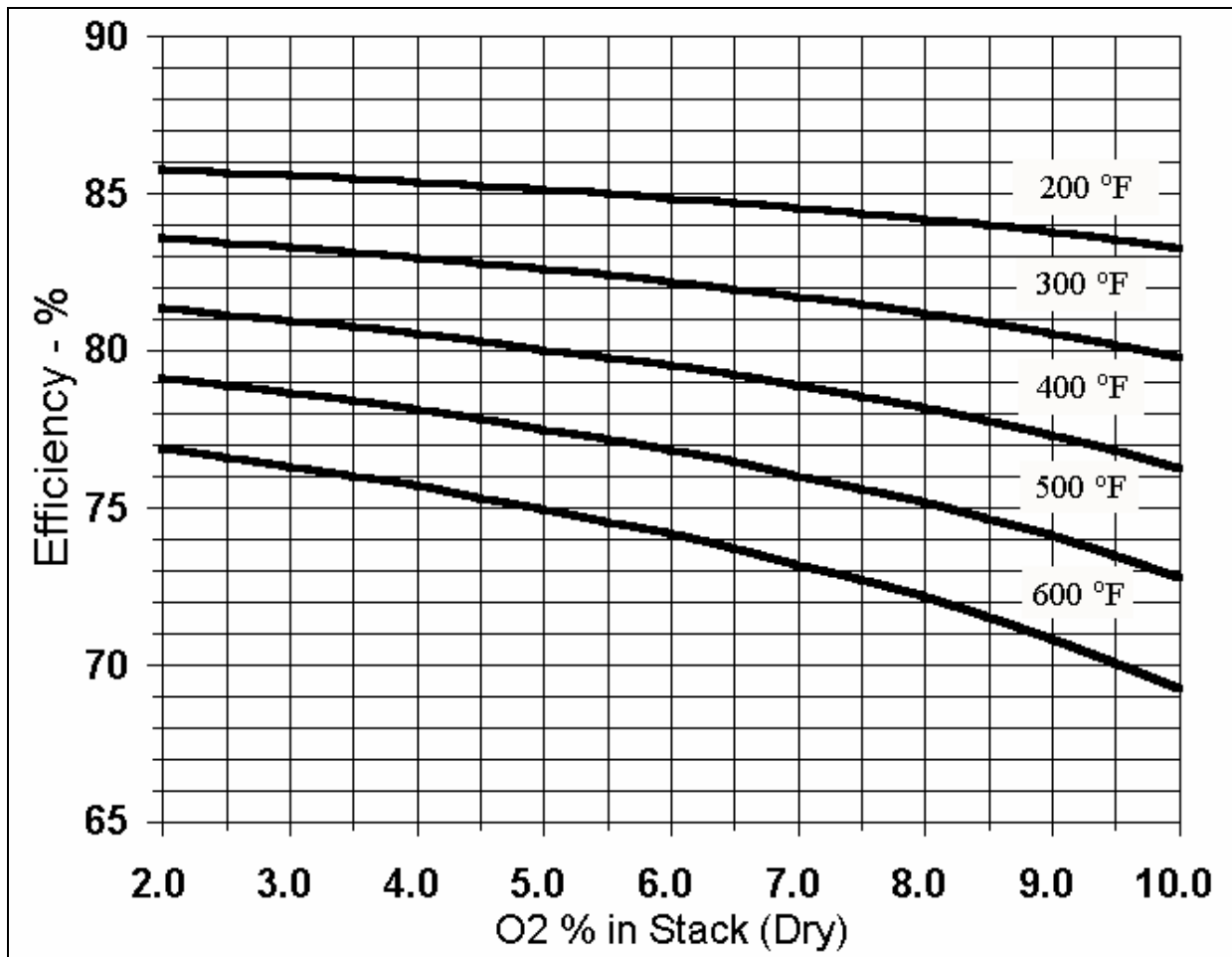

Figure 4: combustion efficiency for Natural Gas as a function of O<sub>2</sub> and net stack temperature

EXCESS AIR	% FLUE OXYGEN	PERCENT OXYGEN IN WINDBOX																			
		1% IFGR	2% IFGR	3% IFGR	4% IFGR	5% IFGR	6% IFGR	7% IFGR	8% IFGR	9% IFGR	10% IFGR	11% IFGR	12% IFGR	13% IFGR	14% IFGR	15% IFGR	16% IFGR	17% IFGR	18% IFGR	19% IFGR	20% IFGR
0.0	0.0	20.7	20.5	20.3	20.1	19.9	19.7	19.5	19.4	19.2	19.0	18.8	18.7	18.5	18.3	18.2	18.0	17.9	17.7	17.6	17.4
5.0	1.0	20.7	20.5	20.3	20.1	20.0	19.8	19.6	19.4	19.3	19.1	18.9	18.8	18.6	18.5	18.3	18.2	18.0	17.9	17.7	17.6
10.0	1.9	20.7	20.5	20.3	20.2	20.0	19.8	19.7	19.5	19.3	19.2	19.0	18.9	18.7	18.6	18.4	18.3	18.1	18.0	17.9	17.7
11.0	2.1	20.7	20.5	20.4	20.2	20.0	19.8	19.7	19.5	19.3	19.2	19.0	18.9	18.7	18.6	18.4	18.3	18.2	18.0	17.9	17.8
12.0	2.2	20.7	20.5	20.4	20.2	20.0	19.8	19.7	19.5	19.4	19.2	19.1	18.9	18.8	18.6	18.5	18.3	18.2	18.1	17.9	17.8
13.0	2.4	20.7	20.5	20.4	20.2	20.0	19.9	19.7	19.5	19.4	19.2	19.1	18.9	18.8	18.6	18.5	18.3	18.2	18.1	17.9	17.8
14.0	2.6	20.7	20.5	20.4	20.2	20.0	19.9	19.7	19.5	19.4	19.2	19.1	18.9	18.8	18.6	18.5	18.3	18.2	18.1	17.9	17.8
15.0	2.7	20.7	20.5	20.4	20.2	20.0	19.9	19.7	19.6	19.4	19.2	19.1	18.9	18.8	18.6	18.5	18.4	18.2	18.1	18.0	17.8
16.0	2.9	20.7	20.5	20.4	20.2	20.0	19.9	19.7	19.6	19.4	19.3	19.1	19.0	18.8	18.7	18.6	18.4	18.3	18.2	18.0	17.9
17.0	3.0	20.7	20.6	20.4	20.2	20.0	19.9	19.7	19.6	19.4	19.3	19.1	19.0	18.8	18.7	18.6	18.4	18.3	18.2	18.0	17.9
18.0	3.2	20.7	20.6	20.4	20.2	20.1	19.9	19.7	19.6	19.4	19.3	19.1	19.0	18.8	18.7	18.6	18.4	18.3	18.2	18.0	17.9
19.0	3.3	20.7	20.6	20.4	20.2	20.1	19.9	19.8	19.6	19.5	19.3	19.2	19.0	18.9	18.7	18.6	18.4	18.3	18.2	18.0	17.9
20.0	3.5	20.7	20.6	20.4	20.2	20.1	19.9	19.8	19.6	19.5	19.3	19.2	19.0	18.9	18.7	18.6	18.5	18.3	18.2	18.1	18.0
21.0	3.6	20.7	20.6	20.4	20.2	20.1	19.9	19.8	19.6	19.5	19.3	19.2	19.0	18.9	18.7	18.6	18.5	18.3	18.2	18.1	18.0
22.0	3.8	20.7	20.6	20.4	20.2	20.1	19.9	19.8	19.6	19.5	19.3	19.2	19.0	18.9	18.7	18.6	18.5	18.4	18.3	18.1	18.0
23.0	3.9	20.7	20.6	20.4	20.2	20.1	19.9	19.8	19.6	19.5	19.3	19.2	19.0	18.9	18.7	18.6	18.5	18.4	18.3	18.1	18.0
24.0	4.0	20.7	20.6	20.4	20.2	20.1	19.9	19.8	19.6	19.5	19.4	19.2	19.1	18.9	18.8	18.7	18.5	18.4	18.3	18.1	18.0
25.0	4.2	20.7	20.6	20.4	20.3	20.1	19.9	19.8	19.7	19.5	19.4	19.2	19.1	19.0	18.8	18.7	18.6	18.5	18.3	18.2	18.1
27.0	4.4	20.7	20.6	20.4	20.3	20.1	20.0	19.8	19.7	19.5	19.4	19.2	19.1	19.0	18.8	18.7	18.6	18.5	18.3	18.2	18.1
30.0	4.8	20.7	20.6	20.4	20.3	20.1	20.0	19.8	19.7	19.5	19.4	19.3	19.1	19.0	18.9	18.8	18.7	18.6	18.4	18.3	18.2
35.0	5.4	20.7	20.6	20.4	20.3	20.2	20.0	19.9	19.8	19.6	19.5	19.4	19.2	19.1	19.0	18.9	18.8	18.7	18.5	18.4	18.3
40.0	6.0	20.8	20.6	20.5	20.3	20.2	20.1	19.9	19.8	19.7	19.5	19.4	19.3	19.2	19.1	19.0	18.8	18.7	18.6	18.5	18.4
45.0	6.5	20.8	20.6	20.5	20.3	20.2	20.1	20.0	19.8	19.7	19.6	19.5	19.4	19.2	19.1	19.0	18.9	18.8	18.7	18.6	18.5
50.0	7.0	20.8	20.6	20.5	20.4	20.2	20.1	20.0	19.8	19.7	19.6	19.5	19.4	19.3	19.2	19.1	19.0	18.9	18.8	18.7	18.6
55.0	7.4	20.8	20.6	20.5	20.4	20.3	20.1	20.0	19.9	19.8	19.7	19.6	19.5	19.3	19.2	19.1	19.0	18.9	18.8	18.7	18.6
60.0	7.8	20.8	20.6	20.5	20.4	20.3	20.2	20.0	19.9	19.8	19.7	19.6	19.5	19.4	19.3	19.2	19.1	19.0	18.9	18.8	18.7
70.0	8.6	20.8	20.7	20.5	20.4	20.3	20.2	20.1	20.0	19.9	19.8	19.7	19.6	19.5	19.4	19.3	19.2	19.1	19.0	18.9	18.9

- Chart use  
Instructions:
- 1 Measure the oxygen content in the flue and air housing (combustion air plus IFGR) on the system being evaluated.
  - 2 Locate on one of the two left hand columns the stack flue oxygen or excess air condition closest to your systems measured values.
  - 3 Travel to the right on the row chosen in 2 to the column closest to the windbox measured oxygen content in your system.
  - 4 Follow the column chosen in 3 to the top of the chart to determine the volumetric IFGR flow under the measured conditions.

Table 3: IFGR recirculation flow determination